

Copyright
by
Benjamin Joseph Liebeskind
2014

**The Dissertation Committee for Benjamin Joseph Liebeskind Certifies that this is
the approved version of the following dissertation:**

Ion Channels and the Tree of Life

Committee:

Harold Zakon, Supervisor

David Hillis, Co-Supervisor

Richard Aldrich

Hans Hofmann

Mikhail Matz

Ion Channels and the Tree of Life

by

Benjamin Joseph Liebeskind, B.A.

Dissertation

Presented to the Faculty of the Graduate School of

The University of Texas at Austin

in Partial Fulfillment

of the Requirements

for the Degree of

Doctor of Philosophy

The University of Texas at Austin

December 2014

Dedication

For my father, John.

Acknowledgements

I would first of all like to acknowledge my advisors Harold Zakon and David Hillis for their guidance, support, and, especially, for the excellent example they set as scientists, scholars, thinkers, and teachers. I also thank my committee members, Richard Aldrich, Hans Hofmann, and Mikhail Matz for their advice and support on this dissertation and on my personal development as a scientist. The members of the Zakon and Hillis labs from 2009 – 2014 have been a wonderful source of feedback and support over the years. I would especially like to acknowledge Thomas Keller, Emily-Jane McTavish, April Wright, Kristin Koenig and Ammon Thompson. This dissertation relied largely on computational skills that I did not possess when I began it. Several individuals put aside time to bring me up to speed, but I would most of all like to acknowledge James Derry, who devotes a huge portion of his own time to helping scientists learn about programming. Finally, I thank my family for their care and support. My mother Julia, my brothers Gabe and Nick, and my excellent wife Louise: you are in my thoughts always.

Ion Channels and the Tree of Life

Benjamin Joseph Liebeskind, PhD

The University of Texas at Austin, 2014

Supervisors: Harold Zakon, David Hillis

The field of comparative neurobiology has deep roots. I will begin by giving an overview of the parts of its history that I feel are most relevant for this dissertation. Within this history lies a wealth of zoological research and penetrating theories that are underutilized by modern evolutionary biologists. The age of whole-genome sequencing provides a perfect opportunity to revisit and perhaps update this corpus to better understand the deep roots of organismal behavior.

The first three chapters of my dissertation will be case studies on the evolution of sodium-selective ion channels. Sodium channels are responsible for much of the electrical signaling in animal nervous systems and muscles, but their evolutionary relationships have not yet been explored with the modern tools of phylogenetics and comparative genomics. Chapter 1 will deal with the classic Na_v channels which create action potentials in nerves and muscles. There I will show that this gene family pre-dates the nervous system and even animal multicellularity. Chapter two will investigate sodium leak channels, which likely create the leak conductance measured by Hodgkin and Huxley. These channels turn out to be close relatives of fungal calcium channels, a relationship which illuminates the evolution of both groups. Chapter three is on bacterial sodium channels and their use as models for other sodium channel types. The final chapter will turn away from sodium channels in particular and discuss the evolution of animal nervous systems by means of ion channel genomics. In that chapter I will show that genomic complements of ion channels that animals with nervous systems possess evolved independently to large degree, and that the early evolution of nervous systems

also involved periods of gene loss. I will end with a more general discussion of convergent evolution, a key theme of this dissertation, and its effect on comparative analyses in the age of genomics.

Table of Contents

List of Tables	xi
List of Figures	xi
INTRODUCTION	1
Proximate and Ultimate Causes of Animal Nervous Systems	2
Proximate	3
The Action Potential	3
Ion Channels	6
Ultimate	8
Phylogenetic Distribution	10
Evolution of the first nervous systems	13
CHAPTERS	20
Chapter 1: Evolution of Sodium Channels Predates the Origin of Nervous Systems in Animals	20
Introduction	20
Results	22
Sodium Channel Homologs in Early-Diverging Animals and Choanoflagellates	22
Phylogenetic Analyses	23
Discussion	24
Rooting the Na _v and Ca _v gene families	24
Voltage-gated ion channels and the animal phylogeny	25
Genetic history – Bilateria	26
Genetic history – Cnidaria	26
Evolution of sodium selectivity and fast inactivation	27
Na _v channels in the animal genetic repertoire	28
Materials and Methods	29
Sources of RNA	29
Gene Amplification and Sequencing	29

Sequence Analysis	30
Acknowledgements	30
Chapter 2: Phylogeny Unites Animal Sodium Leak Channels with Fungal Calcium Channels in an Ancient Voltage-Insensitive Clade	37
Introduction	37
Results and Discussion	39
Methods.....	42
Data Collection	42
Alignment	42
Phylogenetics	43
Data Submission	43
Acknowledgements.....	43
Chapter 3: Independent Acquisition of Sodium Selectivity in Bacterial and Animal Sodium Channels	47
Introduction.....	47
Results and Discussion	48
Methods.....	50
Sequence Collection.....	50
Alignment and Tree Reconstruction	51
Chapter 4: Convergent Evolution of Ion Channel Genome Content in Early Animal Evolution.....	57
Introduction.....	57
Results.....	59
Large Scale Patterns of Gene Gain and Loss.....	59
Convergent Evolution of Gene Content in Animal Nervous Systems	60
Ancestral Reconstructions are Insensitive to Reconstruction Method	62
Findings Extend to Other Nervous System Genes.....	63
Choice of Species Tree	63
Discussion	64

Methods.....	67
Protein Sequences	67
Ancestral Genome Reconstruction	68
Principal Components Analysis.....	70
Program Availability.....	70
CONCLUSION	79
Sodium Channels	80
On the Multiple Origins of the Nervous System	86
Homology	90
BIBLIOGRAPHY	99

List of Tables

Table 4.1: Ion channel families used in this study.	78
---	-----------

List of Figures

Figure I1: Bishop’s neuron.	18
Figure I2: Phylogenetic distribution of action potentials.	19
Figure 1.1: Hypothetical secondary structure of a sodium-channel protein. ..32	
Figure 1.2: Maximum likelihood phylogeny of Na_v and Ca_v channels.	33
Figure 1.3: Phylogeny of Na_v channels with key amino acid sequences.	34
Figure 1.4: Schematic gene tree of the Na_v family with inferred ancestral states of the pore motifs.	35
Figure 1.5: Representative secondary structure predictions for Na_v inactivation gates.	36
Figure 2.1: Phylogenetic tree of opisthokont four-domain ion channels.	44
Figure 2.2: Pore states mapped onto the voltage-insensitive sub-tree.	45
Figure 2.3: Alignment of the voltage-sensing S4 segments from four-domain ion channels.	46
Figure 3.1: Unrooted tree of major ion channel types and ancestral state reconstruction of BaNa_v selectivity filter.	54
Figure 3.2: Two models of the evolution of ion selectivity in the voltage-gated ion channel superfamily.	55
Figure 3.3: Phylogeny of the BacNa_v family and ancestral state reconstructions of selectivity filters.	56
Figure 4.1: Gain and loss of ion channel families in opisthokont evolution. ..71	
Figure 4.2: Ion channel genome content of internal nodes on the animal phylogeny.	72

Figure 4.3: Gain and loss of ion channel genes in the lineage leading to humans.	73
Figure 4.4: Analysis of gene content.	74
Figure 4.5: Gene gain and loss of GPCRs and three non-nervous system genes in the human lineage.	76
Figure 4.6: Support for different species tree topologies based on parsimony scores of gain and loss events.	77
Figure C1: Brief summary of findings.	96
Figure C2: Constructive neutral evolution of a symbolic neural code.	97
Figure C3: Four kinds of homology.	98

INTRODUCTION¹

All organisms react to their environment, but not all have what we call behavior. Discrete, stereotyped movements that occur on relatively short time scales are nearly ubiquitous in single-celled organisms, but are largely absent from multicellular lineages, with animals being the great exception. Other exceptions are humbler, but also fascinating and informative. Early-branching lineages of plants and fungi, for instance, have motile gametes— a characteristic that was lost in most lineages in favor of seeds and spores that disperse by other means— and some adult plants are capable of a few quick movements, notably *Dionaea*, the Venus fly-trap, and *Mimosa*, the “sensitive plant.” If life is to be understood on the broadest taxonomic scales, it is therefore necessary to ask questions about behavior. Above all, we cannot help but wonder at the fact that animals have such rich behavioral repertoires, while other multicellular lineages have none, or next to none.

In all life forms, behaviors are attended at the cellular level by rapid changes in electrochemical gradients. These gradients are maintained by all organisms as a form of potential energy that can be converted into the work of metabolism. But rapid changes in ionic gradients, either locally on the subcellular level, or more globally, can also be turned into signaling cascades that create behaviors. Ionic gradients are maintained by protein pumps and channels. The fact that even some viral genomes encode ion channels attests to the importance of these gradients for the work of life, and suggests that these protein types are almost as ancient as life itself. But some ion channels function mainly in changing the gradients on short time scales, rather than maintaining them. These are the channels that often mediate behaviors. Their selectivity for certain ion species and the conditions under which they tend to open or close determines the role they play.

For my dissertation, I have focused on the evolution of ion channels at the broadest taxonomic scales to better understand behavior at these scales. I have focused

¹ Parts of the Introduction have been previously published in: Liebeskind BJ (2011) *Communicative & Integrative Biology* 4(6):679–683.

mostly on the role that ion channels played in the origin of animal nervous systems, but have been animated by broader questions to which I will make reference throughout. The proliferation of public databases of genomic and transcriptomic data have made possible the comparison of genomes on these broad taxonomic scales. My analyses take advantage of these resources and use comparative genomics and phylogenetics to reconstruct the genetic history of ion channel families that are central to nervous system function.

Sodium is the ion that drives the most important aspects of cellular excitability in animals. I will present three case studies on the evolution of sodium channels as separate chapters. Then, for my last chapter, I turn to a wider analysis that covers most of the other ion channel types that power the nervous system. These chapters will tell a story about the origin, or origins, of animal nervous systems. They will also, I hope, help illuminate some broader principles about the evolution of complexity that I will discuss at the end. While most of the genomic data I use is quite new, the comparative study of animal nervous systems and questions about their origin are emphatically not. I will therefore start by reviewing some of the history of the field to give context to the discoveries made in the last few years by myself and others.

PROXIMATE AND ULTIMATE CAUSES OF ANIMAL NERVOUS SYSTEMS

Two thousand and three hundred years ago, Aristotle claimed that there are at most four types of causes of natural phenomena; four ways to answer the question “Why?” (Sachs 1995). The four causes could be divided into two groups, the material and the formal. Niko Tinbergen and Ernst Mayr reformulated this ancient division for modern biology as “proximate” and “ultimate” causality, corresponding to physiological and evolutionary explanations (Tinbergen 1963; Mayr 1988). Studies of animal nervous systems tend to focus on one or the other type of causality, so I will begin by reviewing them separately. But the two are never truly separate, and much of this dissertation will be serve to illustrate how ultimate causes can force us to see proximate causes in a different light.

PROXIMATE

The Action Potential

Although the involvement of nerves in animal motion was known in antiquity, prior to the 17th century they were thought to be passive conveyors of whatever it was that caused animal motion. Descartes believed that nerves were essentially a hydraulic system, with some type of fluid passing through the nerves into the muscles. This hypothesis came under attack in the mid-17th century by thinkers who believed that the nerve itself moved or was otherwise active in some way. One key set of experiments was performed by a Dutch biologist named Jan Swammerdam in the 1660s. Using an excised frog neuromuscular preparation (the first use of this now classic system) and careful volumetric experiments, Swammerdam showed that muscles did not gain volume when they contracted as Descartes predicted (M. Cobb 2002; Verkhatsky, Krishtal, and Petersen 2006), and concluded that excitability was a motion of nerves themselves:

Therefore the spirit, as it is called, or that subtile [sic] matter, which flies in an instant through the nerves into the muscles, may with the greatest propriety be compared to that most swift motion, which, when one extremity of a long beam or board is struck with the finger, runs with such velocity along the wood, that it is perceived almost at the same instant at the other end (Quoted from M. Cobb 2002).

The nature of the “swift motion,” which Swammerdam had presciently compared to a travelling wave, remained a mystery, but the vibrational model became a rival to the Cartesian school. In a notable conceptual leap, Thomas Willis, perhaps influenced by Gassendi, maintained that muscle generated its force independently of nerves, and that nerves carried only the “symbol of the motion to be performed” (Wallace 2003). This theory was actually a stepping back of the mechanistic philosophy of Descartes in favor of an autonomous faculty of the nervous system connected (by Gassendi at least) to Aristotle’s “sensitive soul,” the principle of motion shared by all animals (Wallace 2003).

The next phase of discovery would then be dedicated to understanding the basis of these nervous signals.

Although Newton speculated in his *General Scholium* to the *Principia Mathematica* that nerve signals may be electrical in nature, it took 80 years for it to be shown experimentally by Luigi Galvani, also using the frog muscle preparation. Galvani's experiments revealed two key properties of excitable tissue: threshold and refractory period after continued excitation. He also postulated the existence of water-filled pores in cell membranes, which he likened to conductors connecting the two sides of a Leyden jar. Experiments on the electrical nature of animal tissue proliferated thereafter, with Matteucci, who measured the "injury current", Walsh, and Faraday playing key roles (Piccolino and Bresadola 2002; Reynolds 2004).

The next major advance was the biophysical measurement of the nerve impulses themselves. Early measurements of the motion of electrical potentials were made by Emile DuBois-Reymond and Hermann von Helmholtz, but Julius Bernstein's invention of the differential rheotome allowed him to make the first true measurements of action potentials in the 1860s (Verkhatsky, Krishtal, and Petersen 2006). In a separate development, careful experiments on muscular contraction had led to the all-or-none theory of nervous excitation by the turn of the 20th century (Lucas 1909; Adrian 1914).

Building on the work of Nernst and Helmholtz on the dynamics of ions in solutions, Bernstein formulated a membrane-based theory of electrical conduction before cell membranes had been conclusively shown to exist (Cole 1968). Like Galvani, Bernstein postulated membranes as an insulating surface between two electrolytic solutions. The potential across them was built up by a selective permeability for potassium ions (K^+), and when the nerve became active, this selectivity disappeared and the membrane became permeable to all ions ("membrane breakdown"). A key notion in Bernstein's new hypothesis was that an action potential is not merely "an electrical sign of the impulse, but is the causal agent in propagation" (Hodgkin 1964), but this had yet to be shown experimentally. Hodgkin showed that this was indeed the case and that the

electrical impulse caused an increase in excitability in the surrounding tissue (Hodgkin 1937a; Hodgkin 1937b). The experimental evidence for the autonomous vibrations of nerves that Gassendi and Swammerdam had postulated 300 years earlier was finally in place.

Bernstein's membrane theory failed to explain one key phenomenon of action potentials, however: rather than just destroy the membrane potential, action potentials overshoot the zero mark, and rose to a potential in the opposite direction of the resting potential. The key to answering this difficulty lay in the discovery of a new type of ionic selectivity involved in action potentials. Overton had shown that sodium was necessary for frog muscle excitation in the action potential (Hodgkin 1964), but it wasn't until the classical experiments on the squid giant axon that the "sodium hypothesis" became the central dogma of electrophysiology. Hodgkin and Katz (1949) showed that Overton's experiments could be recapitulated with voltage-clamp recordings of the squid axon, claiming that the hypothesis of "membrane breakdown" must be rejected in favor of a new hypothesis, one which "presupposes the existence of a special mechanism which allows sodium ions to traverse the active membrane at a much higher rate than either potassium or chloride" (Hodgkin and Katz 1949). Because sodium was an abundant ion in the ocean, but was at a relatively low concentration inside the axon, a sudden increase in sodium permeability would cause sodium to rush into the axon, causing not just depolarization of the potassium-based resting potential but an overshoot beyond zero.

Finally, Hodgkin and Huxley built a mathematical model to show that three processes could explain the action potential in squid giant axons: a sodium current and a potassium current, both functions of voltage and time, and a current that was independent of voltage (a "leak" current) (Hodgkin and Huxley 1952). The Hodgkin and Huxley model could recapitulate the action potential almost perfectly, and predicted several other known properties of nerves, such as "anode break excitation." And although some of their predictions about the nature of the two voltage-dependent processes (now known to be ion channels) were later refuted (Aldrich, Corey, and Stevens 1983), their model

turned out to be so powerful and predictive that it is now rightly seen as the starting point of modern biophysics, where the mechanism of specific molecules is the chief concern.

In this brief review I have completely omitted the history of the anatomy of the nervous system and the structure of nerves themselves. I have instead focused on the history of the action potential and how it became seen as the prototypical proximate cause of animal behavior. The three distinguishing features of action potentials are a threshold for activation, an all-or-none response, and a refractory period. All three features were observed in frog muscle before action potentials were recorded. Action potentials are therefore not merely descriptions of the parts but reflections of the whole. That they have an explanatory power beyond their own functioning can be seen in the recent extension of the term “action potential” to the genomic and hormonal responses in the brain that underlie behavioral changes over longer time periods (Hofmann 2010). These responses also have thresholds, all-or-nothing peaks, and refractory periods. But the electrical action potential, and the ion channels that cause it, are the most basic units; the elements of animal behavior.

Ion Channels

Hodgkin and Huxley’s great contribution was to describe the action potential in terms of underlying processes, which were in turn described by just a few parameters. Their model ushered in a golden period of classical biophysics in which the nature of these underlying processes was described. Even a cursory telling of how these processes were shown to be ion channels, with transmembrane pores, gating processes, and voltage-sensing components, is beyond my scope, so I will confine myself to a brief description of what is currently known about the structure and function of ion channels. Additional descriptions will be given in the chapters.

Ion channels are membrane proteins that provide a pathway to the flow of ions across cell membranes, which are otherwise nearly impermeable. This pathway, or pore, is often selective for certain ion species and can often be opened or closed (“gated”)

under different conditions. Neither case is universally true: some ion channels are not selective or are constitutively open. The combination of these two properties determines the ion channel's function. Ion channels may open in response to heat or light, transducing these forces into electrical signals in the body. Others may respond to intracellular signaling pathways or neurotransmitters. But the most important class of channels for action potential generation is gated by voltage.

Voltage-gated ion channels are a large superfamily that includes the proteins necessary for action potential propagation and many other members of diverse function. Their pore is formed by four re-entrant pore loops that face one another, creating a pathway. They also have a voltage-sensing domain packed with positively charged residues that moves when the cell is brought from its resting voltage to more positive voltages. The force of this movement is then coupled to pore opening, the details of which depend on the channel type. The voltage sensing domain appears in non-channel proteins, such as the voltage-sensitive phosphatase (Murata et al. 2005). Likewise, some channels may have a pore domain without a voltage-sensing domain, so these domains are thought to be modular and their fusion a single evolutionary event (Bertil Hille 2001). Because I will largely be discussing voltage-gated channels, I will refer to the pore and voltage sensing domains together as one domain of a voltage-gated channel.

The largest sub-family of the voltage-gated channels is the voltage-gated potassium channel family (K_v), the members of which are responsible for the re-polarizing current that was observed by Hodgkin and Huxley. K_v currents shape the action potential, set the latency between depolarizations, and reset the cell for the next action potential, and are thereby responsible for much of the complexity in the neural code. These proteins are composed of one domain (i.e. one voltage sensor and one pore loop), and come together to form tetramers in the membrane.

Voltage-gated sodium channels (Na_v) are responsible for the upstroke of action potentials. They are activated by depolarization, and allow sodium ions to rush into the cell, creating further depolarization along the membrane until a potential is reached

beyond which sodium is forced back out of the cell (reversal potential). This runaway process gives action potential their explosive rise, and the reversal potential for sodium sets the height of their peak. The fact that Na_v channels are both activated by depolarization and contribute to it allows action potentials to be both the “causal agent of propagation” and the effect of it. Na_v channels have another important process that keeps action potentials narrow: rapid inactivation. Inactivation did not occur in the K_v s observed by Hodgkin and Huxley, but can occur in other channel types, including some K_v channels (Aldrich 2001). It is a separate process from activation and is caused by a different part of the channel. Like K_v channels, Na_v s require four domains to create a pore, but unlike K_v s, they include all four domains in one protein.

The last voltage-gated group I will discuss, calcium or Ca_v channels, are also four domain proteins. Ca_v s do not play a central role in vertebrate action potentials. Ca^{2+} activates numerous cellular pathways and is kept at very low levels in most cells. Their main role is therefore to transduce the action potential “symbols” into cellular signals (Bertil Hille 2001). These signals include neurotransmitter release, muscle contraction, and gene transcription.

Early phylogenetic work by Strong *et al.* showed that four-domain voltage-gated channels evolved from single-domains channels by two rounds of internal duplication (Strong, Chandy, and Gutman 1993). Strong *et al.* used just one Na_v channel and one Ca_v channel in their phylogeny. I will show later that their results are entirely substantiated by larger datasets that sample a wide range of channels and organisms.

Ion channels play many other roles in the nervous system, and perform numerous roles outside of it, such as osmoregulation. I will explore some of these groups in the final chapter, but will refrain from discussing them here.

ULTIMATE

Not long after the work of Hodgkin and Huxley, George Bishop offered a helpful criticism or moderation of the action potential-centered view of nervous system function

(Bishop 1956). This view, in the extreme version, “deals with nervous systems as digital counting mechanisms, the digits being all-or-nothing impulses.” It was already known that dendrites had graded electrical potentials (as opposed to all-or-none), as did other cells not typically thought of as excitable. Bishop used this data to create a hierarchy of excitable cell types, from those with no excitability, to those with slow graded potentials, and finally to those with both graded and all-or-none spikes in compartmentalized regions of the cell, such as neurons. Many cell types have graded responses, while only a few have all-or-none action potentials. Importantly, the dendrites and axon terminal both have graded responses. A neuron is therefore a “graded response tissue into which has been interpolated an axonal segment, or within which such a segment has been evolved” (Figure II). Bishop interpreted this evolutionarily. Organisms evolved the ability to make all-or-none impulses as they grew larger because graded responses, which are not regenerative, would attenuate over distance. The fundamental work of a neuron, sensation and transmission of a signal, does not require action potentials, but they are a beneficial adaptation for high-fidelity transference of the “symbol of the motion to be performed.”

Bishop’s insight raises some important questions. What were the key steps in the evolution of a nervous system from precursor cells? What was the nature of these precursors? And, if the crucial aspects of nervous systems are shared by non-neural cell types, what then is a nervous system? Fortunately, the early years of electrophysiology were characterized by a zoological and comparative approach that informed these sorts of questions. This was partly necessitated by a need for systems that were tractable given the early stage of the instrumentation. Thus one finds work not just on the large nerves and muscles of myriad invertebrate bilaterians, such as barnacles, squid, leech, *Aplysia*, and crayfish, but on jellyfish, anemones, and even large protists like *Paramecium* (Kamada 1934) and the giant internodal cells of algae such as *Chara* and *Nitella* (Blinks, Harris, and Osterhout 1929). I will first review what studies like these revealed about the

phylogenetic distribution of different ion channel types, and then turn towards theories about the origin of nervous systems.

Phylogenetic Distribution

An early exception to the sodium hypothesis of action potentials came from studies in crustacean muscle, primarily crab (Fatt and Katz 1953; Hagiwara 1983). These muscle fibers have action potentials that depend on calcium for their upstroke rather than sodium. At first, this was viewed as an anomaly, but comparative work revealed a calcium component in the action potentials of many cell types, including vertebrate neurons, and slowly a pattern emerged.

As a rule [sodium] channels are found wherever impulse conduction is the major function of the action potential, while [calcium] channels are found where the action potential is coupled with effector functions such as ciliary reversal, secretion of transmitters and hormones, contractions, and bioluminescence (Hagiwara 1983).

It soon became clear that calcium channels were distributed far beyond the animal kingdom. The ciliate protist *Paramecium* uses a calcium-based action potential to trigger its obstacle avoidance response (Eckert and Brehm 1979; Bertil Hille 2001). The action potential is triggered via stretch receptors (also ion channels) when the protist collides with an obstacle, and the influx of calcium triggers a reversal of the ciliary beat. Calcium currents are also found in plants and brown algae (Taylor and Brownlee 1993). One notable similarity is that fertilization in numerous organisms, including animals, plants, and brown algae, sets off a calcium wave in the oocyte that is crucial for development (Hagiwara 1983). Although only a few studies on fungal cells exist, one such study found a voltage-gated calcium current in the early-branching fungus *Blastocladiella* (Caldwell, Brunt, and Harold 1986). In several lineages, including *Blastocladiella*, but also plants (*Mimosa*) and green algae (*Chara* and *Nitella*), action potentials are triggered by calcium influx but are primarily carried by chloride ions (Beilby 1984; Verret et al. 2010).

An overview of what was known about the phylogenetic distribution of action potentials and ion channels in eukaryotes when I began my dissertation work (2009) is given in Figure I2. It is immediately clear that action potentials are widespread, but that the ion which carries them is not always the same, suggesting independent evolutionary origins. The only lineage which appears not to make use of action potentials is the Dikarya, the “higher” fungi (Hille 2001). Most importantly, sodium-based action potentials are restricted to animals, with the strange exception of the heliozoan protist *Actinocoryne* (Febvre-chevalier et al. 1986). All other lineages use calcium as either the main charge carrier or as a trigger for a chloride action potential.

Figure I2 only concerns the ions that create the upstroke of the action potential. In all cases where there is sufficient information, potassium, presumably carried by animal-like K_v channels, repolarizes the action potential after it fires (Taylor and Brownlee 1993; Caldwell, Brunt, and Harold 1986; Beilby 1984). Even fungi have potassium channels, which they probably use for cell homeostasis (Reid et al. 1995; Bertil Hille 2001). Eukaryotes therefore appear to have complex electrical lives nearly across the board.

Prokaryotes are so small that only a few electrophysiological studies on their membranes have been carried out. It is clear from these studies, however, that prokaryotes make use of channels as well (Martinac, Saimi, and Kung 2008). Stretch receptors and K_v -like channels both appear in bacteria, but very little is known about how they are used (Bertil Hille 2001). However, bacterial channels have become important model systems for channel crystallography (Payandeh and Minor Jr. 2014; Doyle et al. 1998). Recently, a sodium selective channel from bacteria has been discovered and used as a model sodium channel (Payandeh et al. 2011; Ren et al. 2001). I will consider this channel and its usage in Chapter 3.

Viruses have ion channels too. Influenza virions incorporate part of the host membrane in their viral envelope, and in this stolen membrane they express a tiny proton channel (Schnell and Chou 2008). HIV has a similar channel (Schubert et al. 1996). Larger DNA viruses, such as the Chlorella viruses, encode *bona fide* K_v channels,

probably horizontally transferred from host cells (Gazzarrini et al. 2006). It is therefore reasonable to believe that some kind of channel protein was present in the last common ancestor of all life forms, though no extant channel type is likely to be similar to this ancestor.

When I began work on this dissertation, genomic studies had already begun to fill in the gaps in our knowledge. Many of these studies confirmed what already seemed likely: K_v channels are ubiquitous across all cellular life; Ca_v channels are nearly ubiquitous in eukaryotes (but are strangely absent in land plants) (Verret et al. 2010; Wheeler and Brownlee 2008); Na_v channels are only found in animals. Based on the phylogenetic patterns of channels and currents, Bertil Hille hypothesized a scenario of ion channel evolution from a prokaryote ancestor up through extant animal nervous systems (Bertil Hille 2001; Bertil Hille 1989):

Stage 1: Prokaryotes maintain a negative resting potential for energy storage and to drive ATP synthesis. They use channels, such as K_v and chloride channels, primarily for cell homeostasis in the face of osmotic changes. Because they create ATP using the highly negative voltage across their cell wall, the membrane potential must not be greatly disturbed.

Stage 2: The evolution of eukaryotes meant that energy production was largely carried out by mitochondria, freeing up the outer cell membrane for ion-based signaling. Calcium signaling became a eukaryotic specialty, with the evolution of calmodulin, calcium pumps, intracellular calcium channels (such as IP_3Rs), and Ca_v channels being the major innovations.

Stage 3: Animals evolve in oceans where the sodium/potassium ratio and oxygen levels are increasing. Because calcium triggers numerous intracellular pathways, it must be kept at sub-millimolar levels within the cell. Calcium signaling is therefore localized within cells and its flow must be temporally restricted, preventing its use as a driver of continuous, “symbolic” electrical signaling. The evolution of Na_v channels from Ca_v

channels, which they resemble molecularly, allows animals to develop this electrical neural code, and the elaboration of nervous systems is made possible.

Na_v channels therefore emerge as the major innovation in the evolution of animal nervous systems, particularly in the advent of a symbolic neural code. Their evolution from an ancestral Ca_v channel allowed the functions of this ancestor, which included both calcium delivery and signal propagation, to be split between the two new channel types. Na_v channels functioned only in action potential propagation, and Ca_v channels primarily served as calcium delivery systems and signal transducers. Hille's scenario fits perfectly with Bishop's above, so it may further be hypothesized that this sub-functionalization coincided with the evolution of neurons with distinct regions specialized for signal propagation, mediated by Na_vs, and secretion, mediated by Ca_vs.

Evolution of the first nervous systems

Theories about early nervous system evolution were often prompted by electrophysiological work on early-branching animals, particularly cnidarians. Although this work has sadly declined over the years, interest in the evolutionary origins of nervous systems has remained and has been addressed using a variety of approaches. A variety of theories exist and although there has been little progress towards consensus, some important insights have been gained from comparative studies, and this admittedly speculative sub-field has provided a fertile ground for genomics researchers. It will therefore be helpful to briefly outline a few of these speculative theories and to review our inheritance from the golden era of coelenterate neurobiology.

Speculations on the early evolution of nervous systems always suffer from the difficulty in saying with certainty what we mean by a nervous system. As Bullock and Horridge say in their classic textbook:

Since the property of excitability is probably general for living material, and since any collection of like cells can be called a system, it is the combination of

connectedness and specialization for propagating an excited state that we must look for in a nervous system (Bullock and Horridge 1965).

Theories on the emergence of nerves seek to describe the precursor cells from which nerves evolved and the series of steps in between, with particular interest in the “specialization for propagation.”

Early work was largely focused on the evolution of the reflex triad: sensor, connector, and effector. Kleinenberg (1872) suggested that Hydra had “neuromuscular cells” that performed the work of sensor and effector within a single cell (Passano 1963; Moroz 2009). He postulated that cells such as these may have been the ancestral state, which then differentiated into sensory cells, nerves, and muscles, completing the reflex triad. The Hertwigs (1879) disputed his interpretation of these cell types, and claimed that the specialized cells of the reflex triad had arisen independently of one another from separate epithelial cells (Passano 1963; Moroz 2009). Parker’s influential book *The Elementary Nervous System* (1919) posited the evolution of first “independent effectors,” such as myocytes, and then receptors which modified these effectors in some way, and finally of early neurons interposed between sensor and effector that eventually became an integrative network (Passano 1963; Parker 1919; G. O. Mackie 1990). Central to Parker’s theory was the evidence that sponges has independent effector cells that mediated contraction without the need for nerves.

Pantin suggested that nervous systems arose from the need to coordinate the contraction of whole muscular networks, rather than single cells (Pantin 1952). Passano pointed out that endogenous activity was at least as important to nervous systems as sensing and coordination, and therefore claimed that effectors may have “became endogenous activity centers, or *pacemakers*, by developing unstable specialized membrane areas capable of active depolarization” (his italics) (Passano 1963). Mackie, Horridge and others found that many cnidarians could conduct impulses through non-nervous epithelial tissue that was connected via gap-junctions (Mackie 1990; Mackie

2004). This led to the hypothesis that neurons arose from electrically coupled epithelia, an idea which has remained influential (Holland et al. 2013).

Other authors claimed that the first neurons arose from secretory cells (Mackie 1990; Moroz 2009). Unicellular organisms release pheromones and other signals, and this type of signaling may have given rise to paracrine signaling in early animals. Secretory cells may then have developed more specific processes and receptors to fine-tune control of their target effectors.

A recent study is also noteworthy. Jekely suggested that nervous systems may have evolved to control ciliary motion in larvae (Jekely 2011). This is attractive for several reasons. First, most early-branching animals have a biphasic life cycle with an active larval stage. Some sponges, for instance, have phototactic larvae with a far more complex behavioral repertoire than the adult. Second, because larvae have high mortality rates (Maldonado and Riesgo 2008), and because the adult form is often sessile and therefore dependent on larval settlement choices for its survival, much of the selection is likely to fall on the larval form, making it a likely locus for evolutionary novelty (Davies et al. 2014; Nielsen 2008; Liebeskind 2011).

Many of these authors based their ideas on evidence from cnidarians, including anemones (Pantin 1952), medusas (Passano 1963), *Hydra* (Kleinenberg 1872), and siphonophores (Mackie 1986), and they often identify certain structures or faculties of cnidarian nervous systems with the plesiomorphic condition. Mackie has called this practice into doubt (Mackie 1990). His research and others' had shown that medusozoan cnidarians had complex behavior, ganglia, giant axons mediating escape responses (also present in at least one ctenophore (Mackie, Mills, and Singla 1992)), complex sensory structures such as statocysts and eyes (Garm et al. 2006), integrative circuits, pacemakers, fast sodium-based action potentials, many common neurotransmitters, and fast synapses; in other words, all the trappings of invertebrate nervous systems. Mackie called this the "fundamental conventionality of hydromedusan nervous systems" (Mackie 1990) Such findings lead him and others to claim that although cnidarians don't have brains, they do

have central nervous systems whose circular structure is appropriate for a radially symmetrical animal (Satterlie 2011; Mackie 2004).

This complexity, and the deep evolutionary time periods involved, calls into the question our ability to find in cnidarians, and indeed any other extant taxon, the characters of ancestral animals frozen in time. Or, as Bishop (1956) poetically rendered it,

the lowly medusa...has lived and died throughout only a relatively longer temporal expanse than has man, during which it has enjoyed and suffered the same or equivalent vicissitudes as has the self-anointed Lord of Creation; we have all been around a long time.

There is another reason to be suspicious of the idea that cnidarian nervous systems represent an ancestral condition. Moroz suggests that nervous systems may have multiple evolutionary origins (Moroz 2009; Moroz et al. 2014). He brings several lines of evidence to bear. First, complex centralized nervous systems are not clustered on the animal tree. Each of the three major bilaterian lineages, deuterostomes, ecdysozoans, and lophotrochozoans, contain phyla with diffuse nerve-nets and phyla with centralized brains. It is even possible that nervous systems of any kind may not be monophyletically distributed on the tree. Dunn *et al.* finds ctenophores, which have nervous systems, to be the earliest-branching animal lineage, with sponges and placozoans, neither of which have nerves, branching later (Dunn et al. 2008; Hejnol et al. 2009). A second line of evidence concerns the genes expressed in nerves and the development of nervous systems across the tree. There are considerable differences between the developmental genes expressed in the nervous systems of ctenophores, cnidarians (Marlow 2009), and various bilaterian lineages (Pang and Martindale 2008; Marlow et al. 2009). Nor do all nerves originate in the ectoderm, as they do in vertebrates. Some cnidarian neurons originate in endoderm (Marlow et al. 2009).

The developmental evidence is equivocal, however (Ryan 2014; Holland et al. 2013), largely because we have little knowledge about the pace and mode of developmental evolution on large time scales. It is particularly difficult to predict

ancestral states from the presence or absence of a developmental gene in a given tissue. There are well known examples of convergent recruitment of similar genes in convergent structures (“deep homology” (Gehring 2005; Shubin, Tabin, and Carroll 2009)), of conserved gene networks expressed in divergent structures (“phenologs” (McGary et al. 2010)), and of conserved structures lacking conserved developmental networks (“developmental systems drift” (True and Haag 2001)). Due to these difficulties, I have found myself agreeing with Mackie’s wise words: “It now seems most appropriate to ask not which cell lineages originally gave rise to nerves, but where the gene expressed in neurogenesis originally came from” (Mackie 1990).

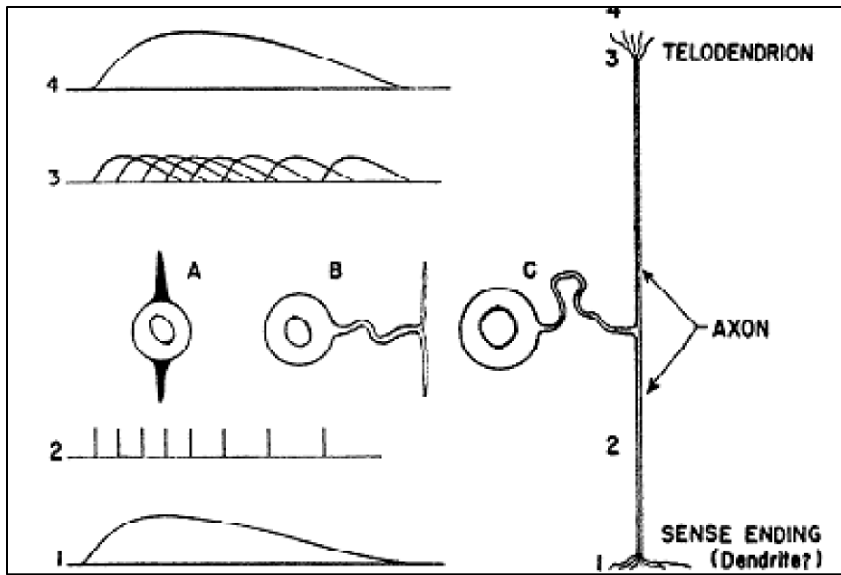

Figure I1: Bishop's neuron.

Evolutionary stages of a neuron (A – C), and location of different kinds of potentials within the neuron (1 – 4). Only axons (2) have all-or-none spikes, other areas have graded potentials. From Bishop (1956).

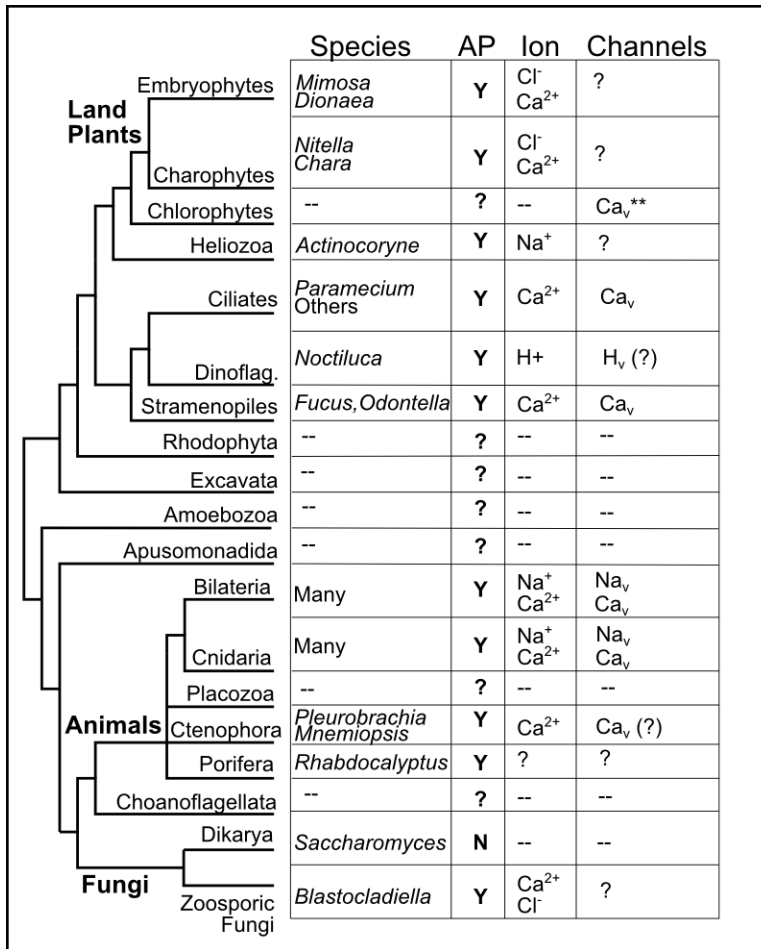

Figure I2: Phylogenetic distribution of action potentials.

The presence of action potentials, the carrier ion, and the channel type presumed to be mediating the action potential across eukaryotes are shown. Data reflects the state of the field in 2009 – 2010. Asterisks indicate channels that are known from genomic evidence alone. Question marks indicate a lack of information or uncertainty.

CHAPTERS

Chapter 1: Evolution of Sodium Channels Predates the Origin of Nervous Systems in Animals²

INTRODUCTION

Early animals radiated explosively in the Precambrian (Rokas, Krüger, and Carroll 2005). This radiation was facilitated by the previous evolution of genes for cell adhesion that presaged the evolution of multicellularity (King et al. 2008). Another key animal innovation was the nervous system, which is present in all but a few animals (i.e., sponges and placozoans). Rapid, specific, long-distance communication among excitable cells is achieved in bilaterian animals and a few jellyfish (cnidarians) through the use of action potentials in neurons generated by voltage-dependent sodium (Na_v) channels. Voltage-dependent calcium (Ca_v) channels evolved in single-celled eukaryotes and were utilized for intracellular signaling. It has been hypothesized that Na_v channels were derived from Ca_v channels at the origin of the nervous system (Bertil Hille 2001), thereby conferring the ability to conduct action potentials without interfering with intracellular calcium. This view was reinforced by the apparent lack of sodium currents in sponges (Leys, Mackie, and Meech 1999).

To test this hypothesis, we searched newly available genome databases from two animals with simple nerve nets (the sea anemone *Nematostella vectensis* and the ctenophore *Mnemiopsis leidyi*), a placozoan with no nervous system (*Trichoplax adhaerens*), a sponge (*Amphimedon queenslandica*), a single-celled eukaryote (the choanoflagellate, *Monosiga brevicollis*), as well as fungi and additional single-celled eukaryotes for homologs of Ca_v and Na_v channels. We then verified the expression of

² Chapter 1 has been previously published in: Liebeskind BJ, Hillis DM, Zakon HH (2011) PNAS 108(22):9154–9159.

these genes in *M. brevicollis* and *T. adhaerens* and examined amino acid changes in these genes throughout the history of animal evolution.

Choanoflagellates are widely distributed unicellular protists (King et al. 2008; Caron et al. 2009) that form the sister group to the multicellular animals (Carr et al. 2008). Placozoans are an early-diverging animal lineage that has been proposed to be sister to the eumetazoa, that is, to all animals with nervous systems (Philippe et al. 2009). But phylogenetic placement of the basal animal lineages is not yet fully resolved (Dunn et al. 2008; Hejnal et al. 2009; Pick et al. 2010; Philippe et al. 2011), and many aspects of placozoan life cycles remain unknown (Pearse and Voigt 2007; Signorovitch, Dellaporta, and Buss 2005). Choanoflagellates and placozoans have received considerable attention due to their possession of numerous genes once thought to be exclusive to higher animals (King et al. 2008; Srivastava et al. 2008; Xinjiang Cai 2008).

Ca_v and Na_v channels have four domains, each of which has a pore loop (Fig. 1.1). A single amino acid at the deepest part of each pore loop is responsible for ion selectivity in the pore. Ca_v channels have acidic residues (E and D) in the pore of domains I-IV (usually E/E/E/E or E/E/D/D). Selectivity for sodium, on the other hand, is based on the residues D/E/K/A in the pore. Sodium channels also have a cytoplasmic loop between their 3rd and 4th domains that swings up and occludes the channel pore just milliseconds after activation (Fig. 1.1). This fast inactivation makes sodium signaling reliable on the millisecond time scale, and mutations at this region in human Nav channel genes cause many well-known pathologies (Goldin 2003). Calcium channels do not have a similar motif at the homologous region. Because of the differences in the amino acids responsible for ion selectivity, and because proteins are likely to be under strong evolutionary constraints along every point of their evolution (Smith 1970), it has been suggested that channels with intermediate pore sequences may exist in extant taxa (Zhou et al. 2004), and some invertebrate channels have been proposed as representatives of these intermediate states (Zhou et al. 2004; Spafford, Spencer, and Gallin 1998). The phylogenetic relationships of these channels are not clear however (Spafford, Spencer,

and Gallin 1998; Nagahora et al. 2000; Hill et al. 2008), and no suggestion of an ancestral metazoan pore state has been put forth.

Our objective was to find voltage-gated ion-channel genes in basal animals and their close unicellular relatives, determine whether the genes are expressed in a few key species, and analyze the evolutionary history of the genes for Na_v and Ca_v channels. We examined pore motifs, inactivation gate sequence, and inactivation gate secondary structure, and then mapped these states onto our phylogeny. This work provides a new view of Na_v and Ca_v channel evolution and the evolution of excitable tissues in animals.

RESULTS

Sodium Channel Homologs in Early-Diverging Animals and Choanoflagellates

We found that the genomes of *Monosiga brevicollis*, *Trichoplax adhaerens*, *Nematostella vectensis*, and *Mnemiopsis leidyi* contain genes for ion channels that group with the Na_v family (Fig. 1.2), and we used these genomic sequences as references for further analyses. We found pairs of Na_v paralogs in *Trichoplax*, *Nematostella*, and *Mnemiopsis* which we name α and β . The genome of the sponge *Amphimedon queenslandica* did not contain Na_v homologs but did have one gene for a Ca_v channel. No Na_v homologs were found in the genomes of *Aspergillus niger*, *Saccharomyces cerevisiae*, or any other fungi in the Joint Genome Institute database. We sequenced the entire open reading frame (ORF) of an mRNA transcript from *Monosiga*, and partial transcripts from the two genes in *Trichoplax*, thereby demonstrating that these genes are expressed. The genes have a pore motif D/E/E/A that is intermediate between Ca_v and Na_v channels and is the same as some previously described invertebrate channels (Zhou et al. 2004; Nagahora et al. 2000).

For one of the paralogs, *Trichoplax* β , only three of the four domains typical to Ca_v and Na_v channels were found in the genome, likely due to a problem with the genome assembly. It is unlikely that a three-domain protein could function as an ion

channel alone, but it is not yet known whether the genome sequencing effort simply missed part of the genome, whether our BLAST analysis misidentified the exons for the last domain, or whether it is actually a splice variant or some other regulatory transcript. The ctenophore Na_v homologs and the sponge Ca_v channel are missing amino acids in the putative pore regions, perhaps also due to incomplete assembly.

Four overlapping segments from choanoflagellate mRNA were compiled to yield 4589 nucleotides, which we believe includes the whole ORF. This sequence was 93.4% identical to the reference sequence obtained with BLAST.

Sequencing of the *Trichoplax* genes yielded 868 bp from the *Trichoplax* α gene, which aligned to the reference with 92.7% identity, and 1062 bp from the *Trichoplax* β gene, which aligned with 91.0% identity. Many of the mis-matches in the *Trichoplax* β segment are from indeterminate nucleotides, and may be due to the fact that this segment was sequenced directly from the PCR products rather than from cloned genes. Although further confirmation of the exact sequences is needed, the presence of these sequences in the mRNA demonstrates that both *Trichoplax* genes are indeed transcribed.

Phylogenetic Analyses

We performed maximum likelihood (ML) analyses on a data set consisting of our sequenced choanoflagellate gene, a putative Ca_v gene from *Monosiga*, and Na_v and Ca_v genes from all major animal lineages and two fungal species, *Aspergillus* and *Saccharomyces* (Fig. 1.2). The phylogenetic placement of the ion channel genes agrees with the well supported parts of the phylogeny for animals, choanoflagellates, and fungi (Philippe et al. 2009; Dunn et al. 2008; Philippe et al. 2011), and the topology was robust to analyses on other platforms and removal of taxa. The placement of the *Amphimedon* Ca_v channel as basal to *Monosiga* Ca_v (Fig. 1.2) is probably an artifact due to long-branch attraction (LBA). This seems likely since the *Amphimedon* branch is long, and *Monosiga* Ca_v is a partial sequence. The placement of these two sequences within Ca_v channels is not consistent with an LBA artifact, however, and is strongly supported by bootstrap analysis, indicating that these are true Ca_v channels. The fungal Ca_v channels were

resolved as the sister-group to all animal and choanoflagellate channels. These results support the hypothesis that Na_v genes evolved from Ca_v genes, since the Na_v family emerges from within animal and fungal Ca_v channels.

Our phylogeny supports the view that placozoans, which have the simplest animal body plan, branched off the animal stem after ctenophores, and are therefore likely to be secondarily simplified. This scenario was found in both Na_v and N/P/Q type Ca_v genes.

Bootstrapping scores indicate strong support for critical nodes of the Ca_v/Na_v gene phylogeny. The position of the choanoflagellate Na_v channel gene at the base of animal Na_v channel genes was supported in 100% of the bootstrap replicates. The bootstrapping analysis also provides strong support for the monophyly of known groups of Ca_v and Na_v channel genes, including the bilaterian Na_v 1 clade and the three major groups of Ca_v channels. The clades containing channels with pore motifs D/E/E/A in both Cnidaria and Bilateria were less well supported in the bootstrap analysis (50–65% of replicates).

DISCUSSION

Rooting the Na_v and Ca_v gene families

The choanoflagellate *Monosiga brevicollis* and the placozoan *Trichoplax adhaerens* express ion-channel genes that group phylogenetically with previously described sodium channels (Fig. 1.2) and have key molecular signatures of sodium channels (Fig. 1.3). Others have proposed that Na_v channels evolved from an ancient Ca_v channel resembling the T-type channels (Bertil Hille 2001), and that there may therefore be extant channels that have properties mid-way between Ca_v and Na_v channels (Zhou et al. 2004). Candidates for such channels have been proposed (Zhou et al. 2004; Spafford, Spencer, and Gallin 1998), but the origin and genetic history of Na_v channels has remained obscure. Our phylogenies show that the Na_v ion channel family originated not only before the advent of the nervous system, but probably even before the advent of multicellularity. These results support the idea that Na_v channels arose from Ca_v

channels, but push back this divergence date to at least the common ancestor of animals and choanoflagellates. This demonstrates that complex systems like excitable tissues can evolve by co-opting existing genes for new functions, rather than by *de novo* evolution of new genes.

Voltage-gated ion channels and the animal phylogeny

The phylogenetic placement of basal animal lineages (sponges, ctenophores, placozoans, and cnidarians) is not yet fully clear, although some placements are less controversial than others. The placement of sponges as sister to all other animals, and of cnidarians as sister to bilaterians, are fairly consistent results (Philippe et al. 2011). The placements of ctenophores and placozoans, however, are less certain. Our results are consistent with the traditional phylogenetic placement of sponges and cnidarians, but place ctenophores, which have a nervous system, outside of the placozoans, cnidarians, and bilaterians (Fig. 1.2, Fig. 1.4). This would suggest that placozoans have lost their nervous system or, much less likely, that the nervous system evolved twice in ctenophores and cnidarians. Although our analysis has relatively strong bootstrap support, it has sparse taxon sampling, which has been shown to meaningfully affect phylogenetic inference (Pick et al. 2010; Hedtke, Townsend, and Hillis 2006) and cannot therefore be considered a decisive species phylogeny.

Also interesting is the apparent loss of Na_v homologs in the sponge *Amphimedon*, an event that may reflect the sedentary life style of these animals. Electrical impulse conduction has not been shown in demosponges, the group which includes *Amphimedon*, but it has been shown in a hexactinellid sponge (Leys, Mackie, and Meech 1999). Hexactinellids differ drastically from demosponges in terms of morphology; further analysis of hexactinellids will be needed to determine if Na_v homologs have been retained in this group.

Genetic history – Bilateria

Our results help clarify the diversity of pore states observed in animal Na_v channels. The topology of our tree suggests that D/E/E/A is the ancestral pore sequence of the Na_v gene family, and that genes with this motif have been retained in every metazoan lineage that we examined, except for sponges, vertebrates, and the cnidarian subgroup Medusozoa (Fig. 1.3, 1.4). The topology of the Na_v 1 and Na_v 2 clades supports the hypothesis that a gene duplication occurred around the time of the bilaterian radiation, and before the split of protostomes and deuterostomes (Hill et al. 2008). The Na_v 1 duplicate evolved a pore motif D/E/K/A and underwent further duplications in early tetrapods, creating the genes for Na_v 1.1-1.9 in mammals (Zakon, Jost, and Lu 2011). The other duplicate retained the ancestral pore motif and was lost in vertebrates.

Genetic history – Cnidaria

Cnidarians diverged before the bilaterian gene duplication and do not have D/E/K/A channels, but the medusozoans have an amino acid substitution in the 2nd domain pore loop, resulting in a clade of channels with the pore motif D/K/E/A. Although the topology of cnidarian channels with glutamic acid (E) in the 2nd domain was not well supported, the clade of D/K/E/A channels was repeatedly found to represent a derived state and was monophyletic with 100% support. In species-tree analyses, the medusozoans share a common ancestor that is not shared with the anthozoans (Philippe et al. 2009; Dunn et al. 2008). The medusozoan subgroups represented here are Hydrozoa (*Polyorchis*) and Scyphozoa (*Cyanea*), both of which have D/K/E/A in the pore, whereas the anthozoan representatives (*Aiptasia* and *Nematostella*) both have D/E/E/A channels (Fig. 3). Our Na_v tree is therefore consistent with proposed species trees, and suggests a lysine (K) substitution in the common ancestor of medusozoans (Fig. 1.4). There is also a *Nematostella* channel whose pore sequence D/E/E/T is unique among sampled ion channels.

Sodium-based action potentials (APs) have been reported in both *Cyanea* (Anderson and Schwab 1983) and *Polyorchis* (Spencer and Satterlie 1981), whereas APs

in anthozoans and ctenophores seem to be carried mostly by calcium (White et al. 1998). The pore motif D/K/E/A has been shown to be less selective for sodium than the D/E/K/A pore but more so than the D/E/E/A pore (Heinemann et al. 1992; Schlieff et al. 1996). Channels with D/E/E/A have a higher affinity for calcium than sodium. The convergence to lysine in different domains of medusozoan and bilaterian ion channels may therefore have resulted from similar evolutionary pressure for sodium selectivity, as this would allow for less disruption of calcium homeostasis since Ca^{2+} is utilized for intracellular signaling in eukaryotes (Bertil Hille 2001). Some medusozoans have concentrated nerve clusters and complex sense organs which likely emerged convergently with the bilaterian central nervous system, as such nerve concentration is absent in anthozoans (Watanabe, Fujisawa, and Holstein 2009). It is not known whether the Na_v genes function in these organs.

Evolution of sodium selectivity and fast inactivation

The pore sequence D/E/E/A is intermediate between Ca_v channel and Na_v channel pore motifs. It may also have an intermediate selectivity between calcium and sodium. The function of D/E/E/A channels in such a wide range of organisms and the reason for their apparent loss in medusozoans and vertebrates remains unknown. Mutation studies of the DSC1 channel (called *Drosophila* Na_v 2 here) showed an effect in olfactory behavior in flies (Kulkarni et al. 2002), but no function for these channels has been suggested in other organisms. The wide-spread retention of these channels suggests that they probably have important, yet possibly divergent, functions (e.g., not all lineages with D/E/E/A channels have olfaction). The sea urchin *Strongylocentrotus purpuratus* is only known to have an Na_v 2 ortholog (Hill et al. 2008).

Hydrophobic sites on the domain III/IV linker that are critical for inactivation are functionally conserved in all the sodium channels that we investigated here, albeit with a wide range of different amino acid combinations at homologous sites (Fig. 1.3). Secondary structure of the inactivation gate is also relatively conserved. Two helices on either side of the hydrophobic triad that forms the “inactivation particle” have been

predicted before and may act to stabilize and direct the inactivation particle as it swings up and binds to the channel (Sirota, Pascutti, and Anteneodo 2002; Catterall 2000). These two helices are present across the Na_v family, but not in the Ca_v families (Fig. 1.5). These findings suggest that all the Na_v homologs presented here may include an inactivation gate, even in the single-celled choanoflagellate.

Na_v channels in the animal genetic repertoire

This study adds to the growing evidence that much of the genetic repertoire for animal development, cell signaling, and even the nervous system was already present in the common ancestor of choanoflagellates and animals. Choanoflagellates have genes for cell-adhesion proteins (King et al. 2008), tyrosine kinases and related proteins (King et al. 2008), proteins related to the post synaptic density of neurons (Burkhardt et al. 2011), and a remarkable complement of calcium signaling proteins (Cai 2008). Some choanoflagellate species have a colonial life stage (Carr et al. 2008), and these genes may function in colony maintenance.

The function of sodium channel homologs in choanoflagellates or placozoans is unknown. They may create calcium-based APs, as suggested by the presence of such APs in ctenophores, but there are other possibilities. Both organisms can inhabit coastal marine areas with abundant fresh water runoff (King et al. 2008; Pearse and Voigt 2007). *Trichoplax* is restricted to warm coastal waters and is known to be sensitive to lowered salinity (Pearse and Voigt 2007). It is possible that the channels act as osmosensors or osmoregulators in these organisms. Choanoflagellates have a long flagellum that they use to swim and to capture prey, and *Trichoplax* has a ciliated ventral layer that it uses for gliding across surfaces. It is possible that the channels control flagellar or ciliary beating through the influx of calcium, which triggers actin, or sodium, which is known to mediate flagellar motors in bacteria (Fukuoka et al. 2009). *Trichoplax* has a layer of contractile fiber cells that form a syncytium, and seem to function as muscle and a nervous system simultaneously (Rassat and Ruthmann 1979). It is possible that the channels function in this dual purpose tissue.

Functional assays of Na_v-channel homologs will shed light on their biological function and on the evolution of Na_v channels as a whole. Determining the ion selectivity of these channels is critical to understanding how sodium selectivity can evolve from calcium selectivity by sequential mutations. Gaining insight into the function of these channels will not only enlighten the history of this protein's "adaptive walk" (Smith 1970), it will also help elucidate the evolution of the nervous system.

MATERIALS AND METHODS

Sources of RNA

M. brevicollis and *T. adhaerens* were cultured in the laboratory using previously described and publicly available protocols. Placozoans were provided by Andreas Heyland. Choanoflagellate cells were fed on the bacteria present in the inoculum, and the placozoans were fed *Cryptomonas* sp. (LB 2423) from the University of Texas at Austin collection of algae (UTEX). To extract RNA from *M. brevicollis*, we mixed and centrifuged 2 ml of the culture medium at 4°C. Whole RNA was extracted using a RNA STAT-60 kit (Tel-Test, INC.) and then stored at -20°C. The same protocol was used to isolate and store RNA from 15 *T. adhaerens* individuals that had been kept in algae-free seawater for 2 days to reduce the chance of contamination with algal RNA.

Gene Amplification and Sequencing

Specific primers were designed from the BLAST sequences for RT and PCR reactions. RT reactions were conducted with a SuperScript II kit (Invitrogen) using both specific and poly-T primers to prevent bacterial RNA contamination. PCR reactions were carried out with the following cycle for 39 repetitions: Denaturation at 94° (30 sec), annealing at a primer-specific temperature (30 sec), elongation at 72° (1 min/kb). This cycle was preceded by an initial denaturation at 94° for 3 min 10 sec, and followed by a final elongation at 72° for 7 min. PCR products were visualized and purified with gel electrophoresis, and then cloned using a TOPO cloning kit (Invitrogen) and One Shot

Top 10 (Invitrogen) chemically-competent *E. coli*. We sequenced the *M. brevicollis* gene in four overlapping segments using vector-specific primers after cloning.

Sequence Analysis

We performed a maximum likelihood phylogenetic analysis using the translated mRNA sequence from *M. brevicollis*, and amino acid sequences from online databases for the other organisms. The latter was obtained either from cataloged, known channels, or from BLAST searches of available genomes. Amino acid sequences were aligned using the E-INS-I strategy in MAFFT (Kato et al. 2005). We used the GUIDANCE algorithm available on the GUIDANCE server to remove columns that had a score below 0.377 from the alignment (Penn et al. 2010). Maximum likelihood phylogenetic analysis and bootstrapping were performed in Garli (Zwickl 2006), using a model of amino acid replacement selected using the Akaike Information Criterion in Prottest (Abascal, Zardoya, and Posada 2010). The model of protein evolution selected in the Prottest analysis was WAG+I+G+F (Whelan and Goldman model, with invariant sites, parameter for gamma distributed rate heterogeneity, and amino acid frequencies matched to the observed data). The maximum likelihood tree was obtained using Garli set to use the WAG+I+G+F model. The full amino acid alignment was analyzed for 4 search repetitions operating across 5 million generations each. 100 bootstrap samples were collected using a halved topological termination condition, as recommended in the Garli manual, and a stop time of 1 million generations. All bootstrap outputs were analyzed in PAUP (Swofford 2003).

Secondary structure of the inactivation gate region was examined using the online server PsiPred (Bryson et al. 1995).

ACKNOWLEDGEMENTS

We thank Andreas Heyland for providing stocks of *Trichoplax*, Nicole King and Vicki Pearse for helpful discussion and advice, Marianna Grenadier for figure editing, and Emily McTavish, Thomas Keller, and Shannon Hedtke for advice on computational

analysis. We also thank Andy Baxevanis and Joseph Ryan in the Division of Intramural Research, National Human Genome Research Institute, National Institutes of Health for providing sequences from the *M. leidy* draft genome. Finally, we would like to acknowledge Bertil Hille and Edmund Brodie III for helpful suggestions on the manuscript. Laboratory work was funded by National Institute of Health (R01GM084879).

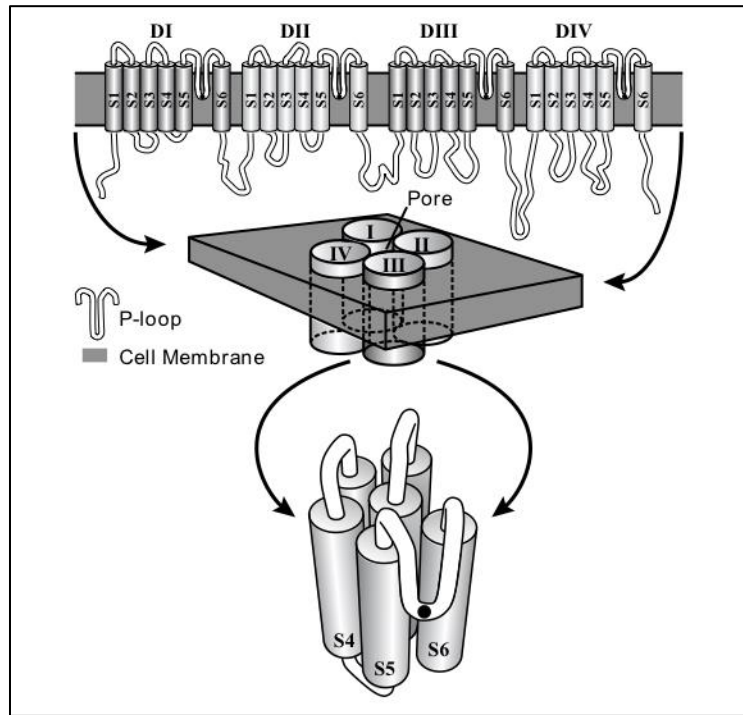

Figure 1.1: Hypothetical secondary structure of a sodium-channel protein.

The top figure shows the trans-membrane domains (DI–DIV), their component segments (S1–S6), and their connecting loops (in white). The pore loops (P-loop), which dip down into the membrane, form the ion-selectivity filter. The inactivation gate resides on the long loop between DIII/S6 and DIV/S1. The middle figure shows how the domains cluster to form the protein and its pore, and the lower figure shows the fine structure of one of domains with the pore loop in the foreground. The black dots on the pore loops in the top and bottom figure represent the location of the amino acids which makes up the pore motif.

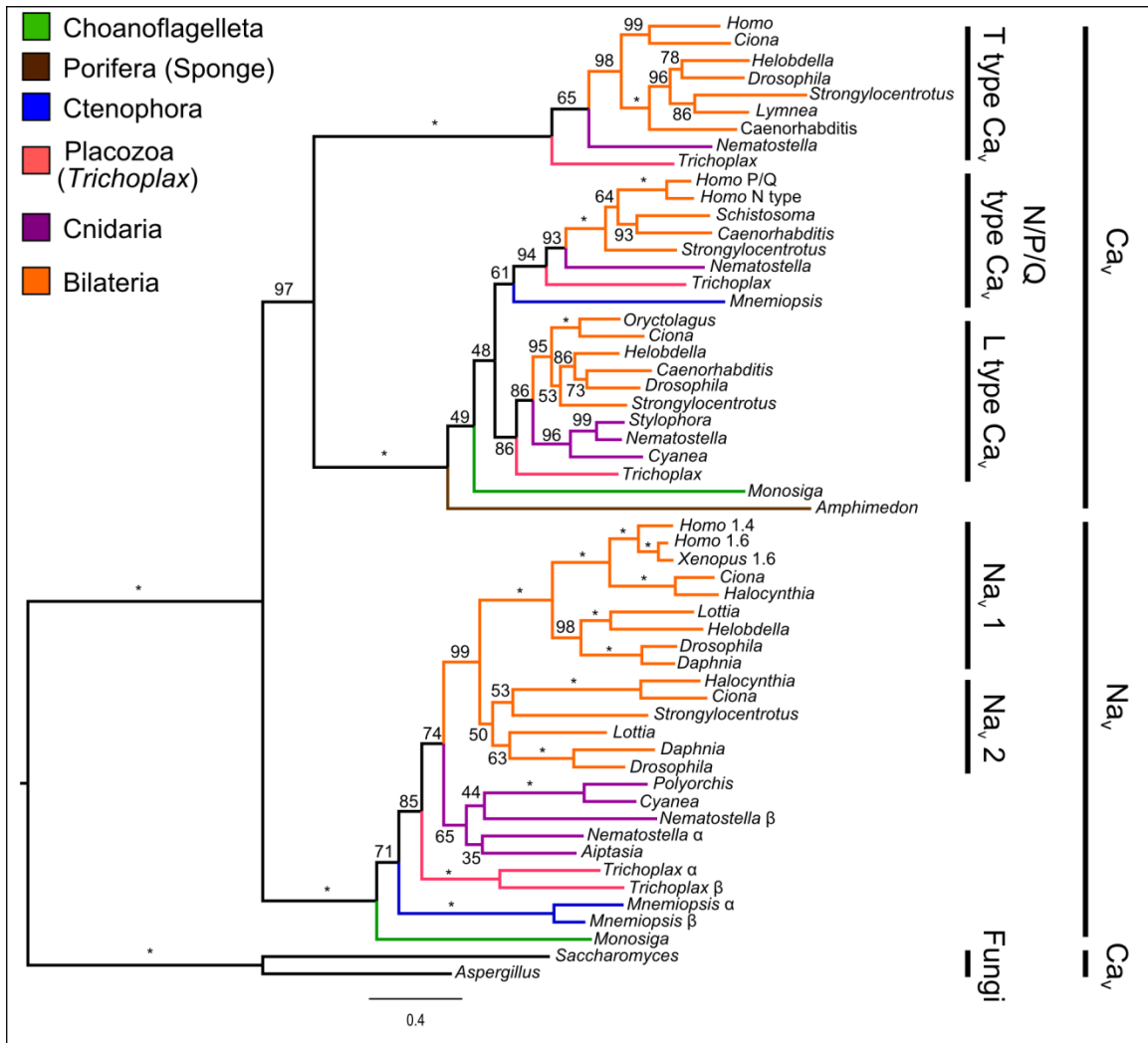

Figure 1.2: Maximum likelihood phylogeny of Na_v and Ca_v channels.

Bootstrap scores are indicated on branches, with stars indicating scores of 100%. Clades corresponding to major ion channel groups are detailed on the right.

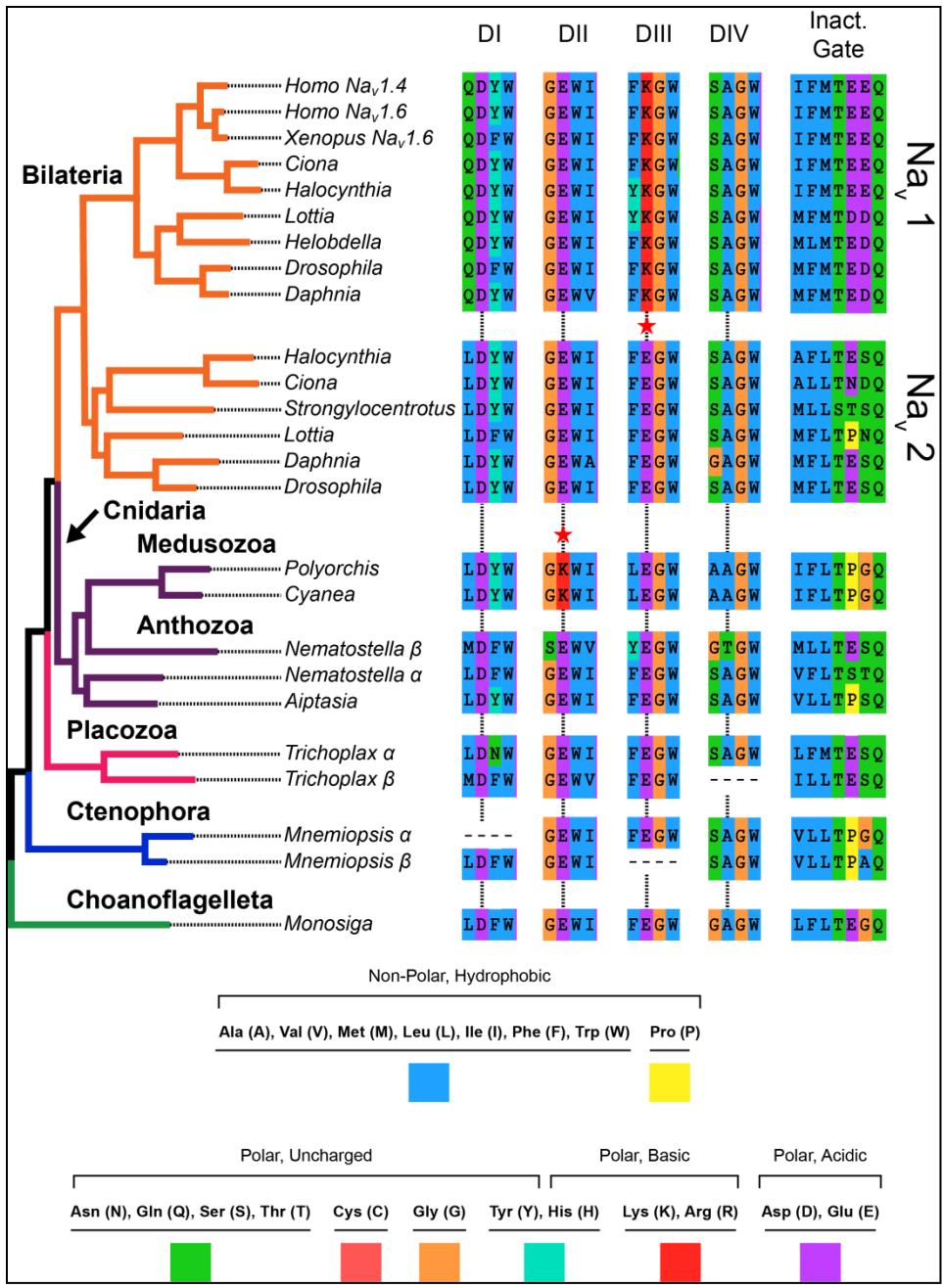

Figure 1.3: Phylogeny of Na_v channels with key amino acid sequences.

Taxa are color coded the same way as in Figure 1.2. The amino acids are alignments of the pore loops of all four domains (DI, DII, etc.) and the critical inactivation particle on the inactivation gate. The critical amino acids in the pore are indicated by the vertical lines, and there are red stars next to convergent lysines (red “K”s). Note the functional

conservation of the hydrophobic triplet called the “inactivation particle” (1st three amino acids on the inactivation gate).

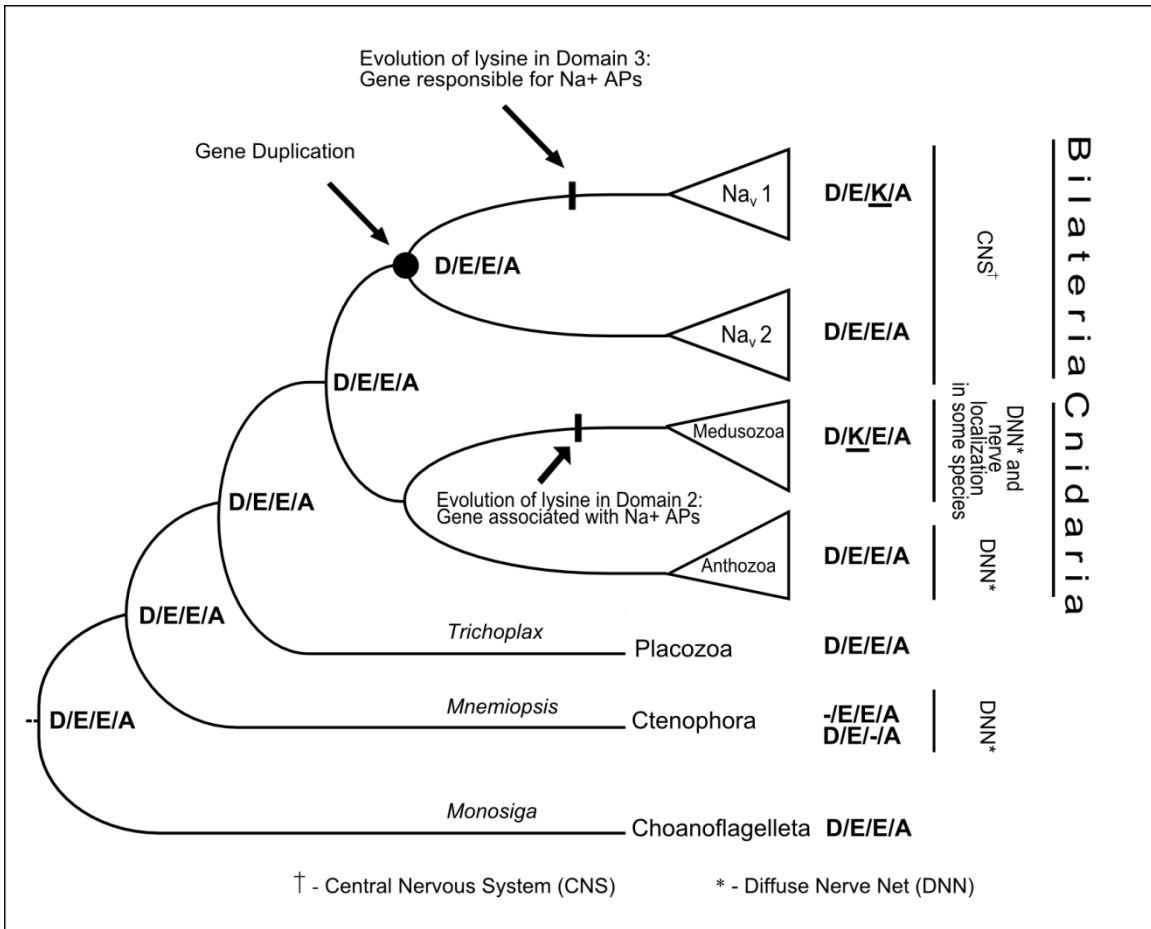

Figure 1.4: Schematic gene tree of the Na_v family with inferred ancestral states of the pore motifs.

The gene duplication leading to the bilaterian Na_v 1 and Na_v 2 clades is noted, as are the points where we reconstruct fixation of lysines (K) in pore loops. Taxonomic information and information about the nervous system is also given. The *Nematostella* β and *Trichoplax* β genes have been left out for simplicity, but their addition would not change the proposed ancestral states. Pore states for both *Mnemiopsis* genes are shown because neither has a complete pore motif.

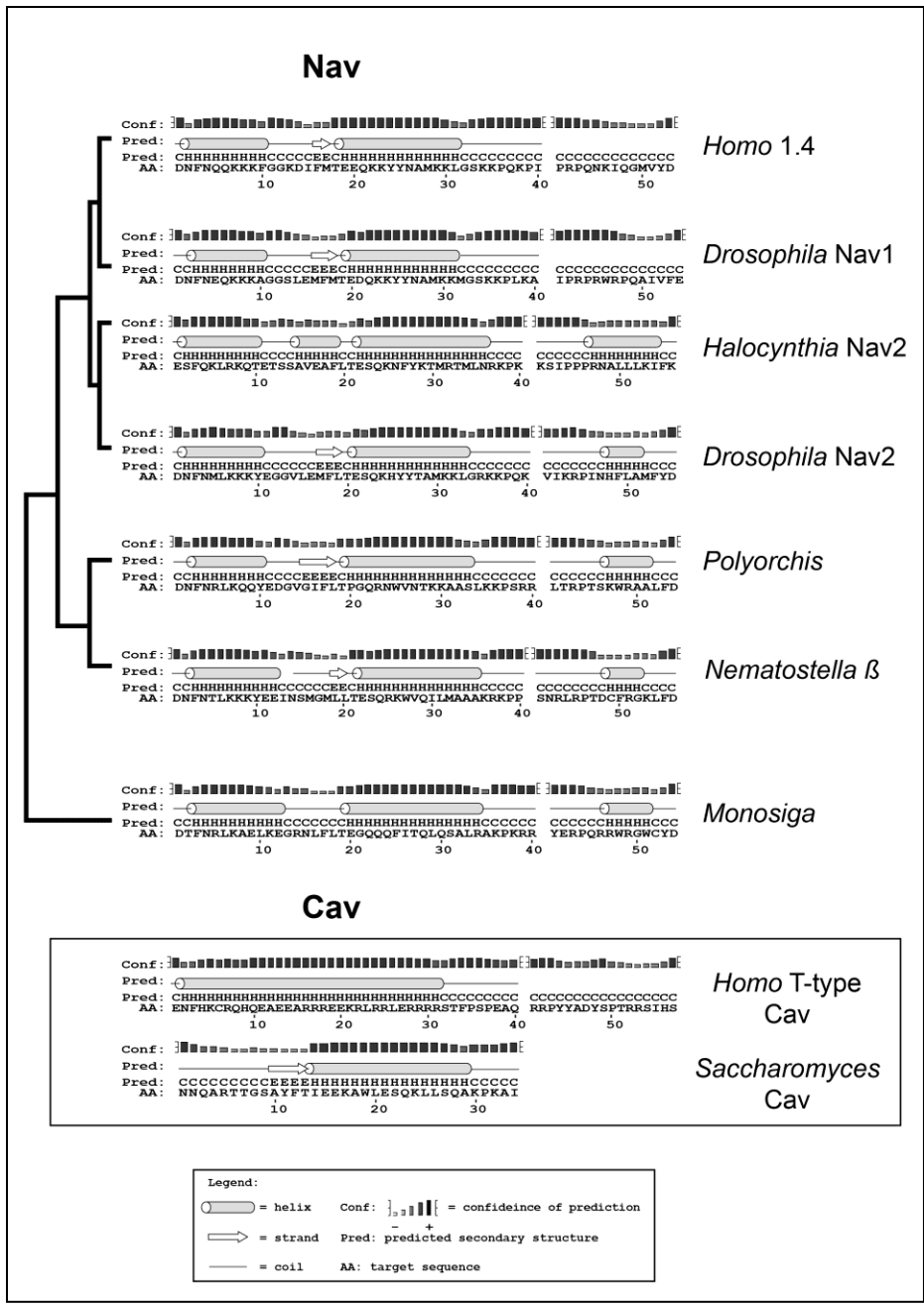

Figure 1.5: Representative secondary structure predictions for Na_v inactivation gates.

The predictions are mapped onto a simplified phylogeny. The two major helices are present in all Na_v s but absent in Ca_v s.

Chapter 2: Phylogeny Unites Animal Sodium Leak Channels with Fungal Calcium Channels in an Ancient Voltage-Insensitive Clade³

INTRODUCTION

The eukaryotic super-group Opisthokonta contains two large kingdoms with very different life styles: fungi and animals (Parfrey et al. 2011; Torruella et al. 2011). The most obviously distinguishing feature of animals is the elaboration of motile behavior in adults, facilitated by the evolution of nerves and muscle. Recent studies have used comparative genomics and phylogenetics to examine the history of nervous system genes and show how this history bears on eukaryotic diversity (Cai and Clapham 2011; Emes and Grant 2011; Liebeskind, Hillis, and Zakon 2011; Cai 2012). We continue this project, focusing here on the evolution of opisthokont four-domain ion channels.

The voltage-gated ion channel family includes the potassium, calcium (Ca_v), and sodium (Na_v) channels that mediate the neural code by creating action potentials (Hille 2001). Ca_v and Na_v channels have four domains, each with six transmembrane segments. Each domain has a pore loop between the fifth and sixth segments, forming a pore motif of four amino acids that determines ion selectivity. It is hypothesized that Ca_v channels arose from single domain potassium channels by internal duplication at the base of eukaryotes (Hille 2001), and that Na_v channels arose from the Ca_v family just before the origin of opisthokonts (Cai 2012).

Sodium leak channels, or NALCN (**NA⁺ Leak Channel Non-selective**), are four-domain channels that are built on the same six trans-membrane segment domain as their better studied relatives, the Ca_v and Na_v channels, but are voltage-insensitive. NALCN channels have been implicated in numerous rhythmic behaviors (Ren 2011) such as breathing in mice (Lu et al. 2007), crawling in *C. elegans* (Pierce-Shimomura et al. 2008), and circadian rhythms in flies (Nash et al. 2002).

³ Chapter 2 has been previously published in: Liebeskind BJ, Hillis DM, Zakon HH (2012) Mol Biol Evol 29(12):3613–3616.

NALCN channels maintain and regulate firing rates in rhythmically firing neurons by modulating neuronal resting potential (Lu et al. 2007). As they leak sodium into the cell, the membrane becomes depolarized from the very negative potential set by the efflux of potassium, and moves towards the threshold at which Na_v channels begin to open. NALCN channels may therefore be thought of as affecting the gain of the neuron: the more NALCN channels are open, the more likely an input is to initiate firing (or that a rhythmic neuron will continue to fire). Although they are insensitive to voltage, their open state can be affected by the presence of various neurotransmitters and by calcium, and they rely on accessory proteins for their function (Lu et al. 2009; Swayne et al. 2009; Lu et al. 2010).

It has been shown previously that NALCN channels diverged from voltage-gated channels before the diversification of Ca_v and Na_v channels (Lee, Cribbs, and Perez-Reyes 1999), and have some similarities to the lone family of fungal four-domain channels (Hong et al. 2010; Ren 2011). These fungal channels are strongly selective for calcium, but like NALCN are voltage-insensitive and rely on an accessory protein for gating (Teng et al. 2008; Hong et al. 2010). Fungal calcium channels have been implicated in mating in yeast (Paidhungat and Garrett 1997), calcium-store restoration in the meningitis-causing fungus *Cryptococcus neoformans* (Liu et al. 2006, 1; Hong et al. 2010), and ascospore discharge in the plant pathogen *Gibberella zeae* (Hallen and Trail 2008). These channels will be called fungal calcium channels here for simplicity, but there are other calcium channels in fungi that are not homologous to animal four-domain channels (Zelter et al. 2004).

In this study, we sought to clarify the phylogenetic relationships between the major lineages of opisthokont four-domain ion channels. We use this phylogenetic information to infer the historical timing of key amino acid replacements that may have had large-scale effects on opisthokont evolution. This study builds upon and synthesizes previous work which identified the unique place of voltage-insensitive ion channels but

did not place this information in the context of opisthokont evolution (Paidhungat and Garrett 1997; Lee, Cribbs, and Perez-Reyes 1999; Ren 2011).

RESULTS AND DISCUSSION

We used BLAST searches to identify NALCN homologs in some of the oldest animal lineages, including cnidarians (*Nematostella vectensis*), placozoans (*Trichoplax adhaerens*), and sponges (*Amphimedon queenslandica*). We also found four-domain fungal channels in diverse fungal lineages, including the early-branching Zygomycota (*Phycomyces blakesleeanus*, and *Mucor circinelloides*), and Blastocladiomycota (*Allomyces macrogynus*). Fungal calcium channels and NALCN homologs were notably absent in single-celled opisthokont genomes. We aligned the new sequences with previously identified Ca_v and Na_v channels from animals, choanoflagellates, and the apusozoan protist *Thecamonas trahens* (Liebeskind, Hillis, and Zakon 2011; Cai 2012), thought to be the sister group to opisthokonts (Torruella et al. 2011). Support for a monophyletic apusozoan clade is weak (Cavalier-Smith and Chao 2003), but we will refer to the apusomonad *Thecamonas* as an apusozoan to be consistent with the online database from which the sequence came and with recent literature (Torruella et al. 2011).

Phylogenetic analysis using maximum likelihood and Bayesian methods places fungal calcium channels and NALCN-like sequences within a well-defined clade to the exclusion of voltage-gated Ca_v and Na_v sequences (Fig. 2.1). The topology was robust to model choice and estimation method and is consistent with known species trees (Torruella et al. 2011). This voltage-insensitive clade split from the voltage-gated group that includes animal Ca_v and Na_v channels before the divergence of the fungal and animal lineages.

Unlike Na_v and Ca_v channels, which underwent several rounds of duplication in animals (Liebeskind, Hillis, and Zakon 2011; Zakon, Jost, and Lu 2011), NALCN channels were found in single copy in most species examined (Fig. 2.1). The sponge *A. queenslandica*, the cnidarian *N. vectensis*, and the nematode *C. elegans* (Pierce-Shimomura et al. 2008) are exceptions to this rule and each have two genes. This is

notable because neither sponges nor nematodes have Na_v channels. The presence of NALCN in all examined species has been noted previously in bilaterians (Ren 2011), and this finding extends this trend to non-bilaterians.

Non-bilaterian NALCN channels do not have the same pore sequence as previously identified NALCN channels (E/E/K/E or E/K/E/E). NALCN channels in *Amphimedon*, *Trichoplax*, and *Nematostella* have E/E/E/E in the pore, identical to high voltage-activated Ca_v channels (Fig. 2.2). The lysine ('K') in the third domain of NALCN channels is thought to render the channels non-selective amongst cations (Lu et al. 2007) because single lysine substitutions in wild-type (E/E/E/E) Ca_v channel pores eliminate selectivity for calcium over monovalent cations (Yang et al. 1993). It is therefore likely that non-bilaterian NALCN channels actually function as calcium-permeable channels. These findings reinforce the view that changes in ion channel selectivity were major steps in the evolution of complex nervous systems in animals (Bertil Hille 2001; Liebeskind, Hillis, and Zakon 2011; Liebeskind 2011).

The earliest branching fungal calcium channel (*Allomyces*) also had an acidic pore motif (Fig. 2.2), which suggests that the common ancestor of all voltage-insensitive channels had an acidic pore and was permeable to calcium. The most diverse lineages of fungi (ascomycetes and zygomycetes) then fixed for polar uncharged amino acids (N or Q) in the first domain pore loop (Fig. 2.2). Basidiomycetes are another diverse fungal clade that was not sampled here, but have an identical pore to their sister group, the ascomycetes (data not shown). Unlike animal Ca_v channels, fungal calcium channels with an N/E/E/E pore are not permeable to sodium even in the absence of calcium (Hong et al. 2010). Because fungal calcium channels are necessary for survival in low-calcium environments in several fungal lineages, this may be adaptive (Liu et al. 2006, 1; Hong et al. 2010, 1). The fixation for N or Q in the pore accompanied a loss of swimming zoospores in fungi at the blastocladiomycete/zygomycete boundary. This is notable because calcium channels underlie mating in yeast and ascospore bursting in *Gibberella*

zeae (Fischer et al. 1997; Hallen and Trail 2008), and may therefore be involved in mating behavior in many other fungi.

Thus the early branching lineages of both NALCN and fungal channels retained acidic motifs, but the most diverse groups of sampled animals and fungi, (bilaterians in animals, and ascomycetes and zygomycetes in fungi) evolved different pore motifs early in their diversification. How these changes may have affected the evolution of animals and fungi will require characterization of channels that group close to the roots of these groups.

Characterized NALCN and fungal calcium channels are voltage-insensitive (Lu et al. 2007; Hong et al. 2010), and all channels in this clade had reduced numbers of voltage-sensing residues relative to voltage-gated channels (Fig. 2.3). This suggests that the homolog in the common ancestor of animals and fungi was not voltage-gated and that voltage-insensitivity is therefore a shared, derived character of this clade. Since both fungal calcium channels and NALCN rely on accessory proteins for their function, it is also likely that this characteristic evolved at the base of the clade. Although we found no obvious sequence similarity between the known accessory proteins of NALCN and fungal calcium channels, it seems likely that modulation by other proteins facilitated the loss of voltage-sensitivity in an ancestral channel and that the modulating proteins themselves have changed over time.

Figure 2.1 is rooted at the midpoint. To get a more reliable rooting, we used voltage-insensitive and voltage-gated channels as queries to search non-opisthokont genomes for a channel that diverged prior to the diversification of the channels represented in Figure 2.1. Most major eukaryote lineages have four-domain channels, many of which are hypothesized to be calcium channels on the basis of their pore motifs (Verret et al. 2010; Prole and Taylor 2011). We added 11 non-opisthokont sequences that had good coverage of taxa and channel types to the phylogeny in Figure 2.1.

These sequences could not be reliably placed within the phylogeny, however, making root placement and the status of the *Thecamonas* channels uncertain. However,

rooting between voltage-gated and voltage-insensitive channels, as in Figure 2.1, produces a more parsimonious pattern of gene loss in fungi than rooting with either voltage-gated group (1 loss instead of two). Some non-opisthokont channels were identical to animal Ca_v channels in their pore sequence, but had Na_v-like inactivation loop motifs (Smith and Goldin 1997). These enigmatic similarities cannot be adequately explained at present, but suggest a complicated evolutionary history.

Our phylogeny suggests that an ancient loss of voltage sensitivity in a lineage of four-domain ion channels and key amino acid replacements affecting ion selectivity in this lineage were both factors in the diversification of fungi and animals. This phylogenetic information clarifies the evolution of voltage-insensitive four-domain channels and suggests fungal calcium channels as possible models for future NALCN research.

METHODS

Data Collection

Human or mouse sequences were used as queries to search for orthologs of NALCN and *Saccharomyces cerevisiae* queries were used to search for orthologs of fungal calcium channels. We used BLASTp to search NCBI's non-redundant protein database, the Joint Genome Institute's genomes, or the Origins of Multicellularity protein database (Altschul et al. 1997). Putative orthologs were reciprocally BLASTed into the genome from which the original query came to verify strict orthology between subject and query.

Alignment

We used the GUIDANCE server (with the MAFFT option) to make alignments and to prune the alignments of the most unreliable columns, leaving 50% of the columns (Kato et al. 2005; Penn et al. 2010). The alignment of one sequence from the apusozoan *Thecamonas trahens* was found by GUIDANCE to be unstable, and was discarded. Since GUIDANCE often leaves areas with a high proportion of indels, we also removed

columns that were more than 50% gapped using the Gap-Strreeze server (Los Alamos HIV Sequence Database: <http://www.hiv.lanl.gov/content/sequence/GAPSTREEZE/gap.html>). For ion channels, this combined strategy produced alignments that consisted mainly of the trans-membrane regions, pore loops, and the intra-cellular linker between domains III and IV.

Phylogenetics

We used both maximum likelihood (ML) and Bayesian methods to estimate phylogenies. The Whelan and Goldman model with a class of invariant sites (+I), 4 gamma distributed rate categories (+G), and estimated amino acid frequencies (+F) was chosen by the Akaike information criterion in Prottest as the best model and was used for ML inference (Whelan and Goldman 2001; Abascal, Zardoya, and Posada 2010). ML and bootstrap trees were estimated in Garli (Zwickl 2006) with the final ML tree being the best of four independent replicates. The bootstrap proportions are out of 100 pseudo-replicates. Bayesian estimation was done using PhyloBayes 3.3 under default ‘automatic stopping-rule’ conditions (Lartillot and Philippe 2004). The authors of PhyloBayes recommend the CAT-GTR or CAT-Pois models for datasets larger than 1,000 aligned columns. Both of our datasets are over this threshold, so we chose the default CAT-Pois model. The mean numbers of site-classes assigned by the CAT model were averaged over the posterior distributions of both chains pooled together. The mean of the data sets were 84.84 and 101.2 for the data sets in Figures 2.1 and the extended dataset mentioned above, respectively.

Data Submission

Data sets, alignments and trees used for phylogenetic analysis were submitted to TreeBase (accession URL: <http://purl.org/phylo/treebase/phyloids/study/TB2:S12662>)

Acknowledgements

We would like to thank Emily McTavish, Thomas Keller, April Wright, and Ammon Thompson for helpful comments on the initial manuscript, and associate editor

Dr. Andrew Roger and two anonymous editors for thoughtful reviews. We would also like to acknowledge the Broad Institute and their Origins of Multicellularity project for making the genomes of several taxa used in this study available to the public. Work was funded by National Institute of Health Grant R01GM084879.

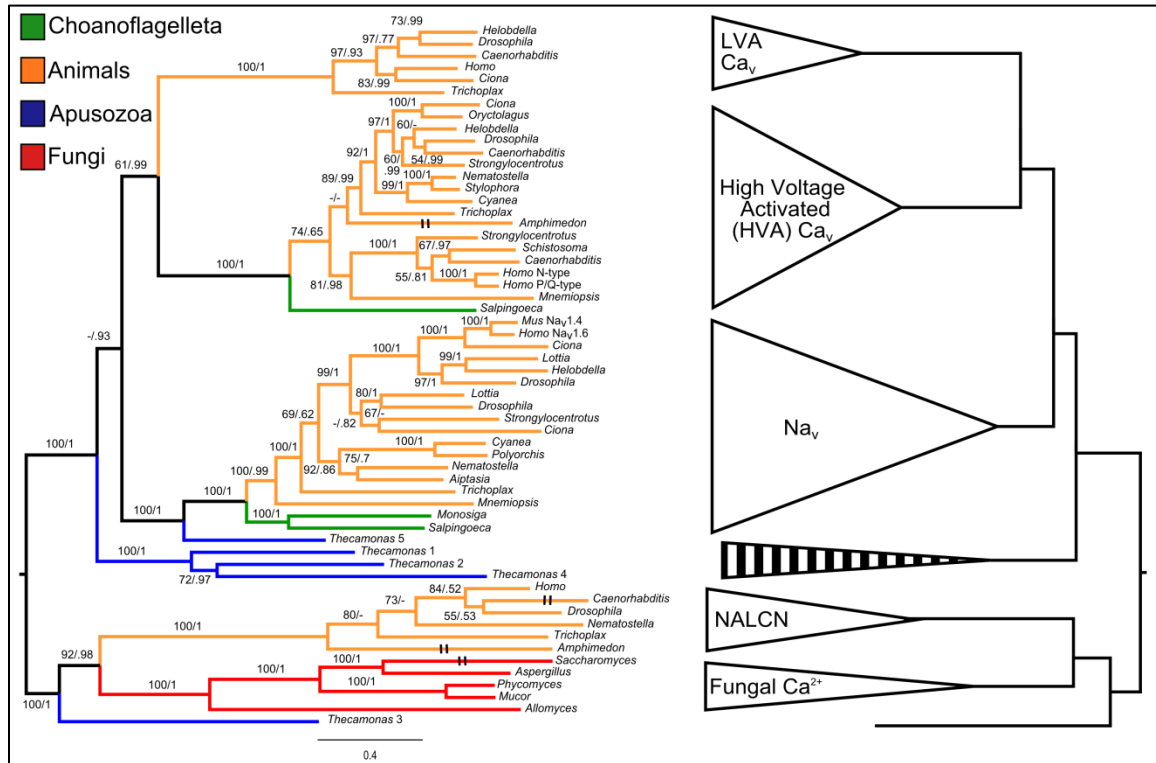

Figure 2.1: Phylogenetic tree of opisthokont four-domain ion channels.

NALCN and four-domain fungal calcium channels group together in a well-supported clade. Bootstrap proportions and posterior probabilities are reported for each branch. The cartoon on the right shows major groups of channels, including low- and high-voltage activated Ca_v channels (LVA and HVA, respectively), Na_v channels, NALCN, and four-domain calcium channels. Hash marks on the left-hand tree denote branches that have been shortened for ease of display.

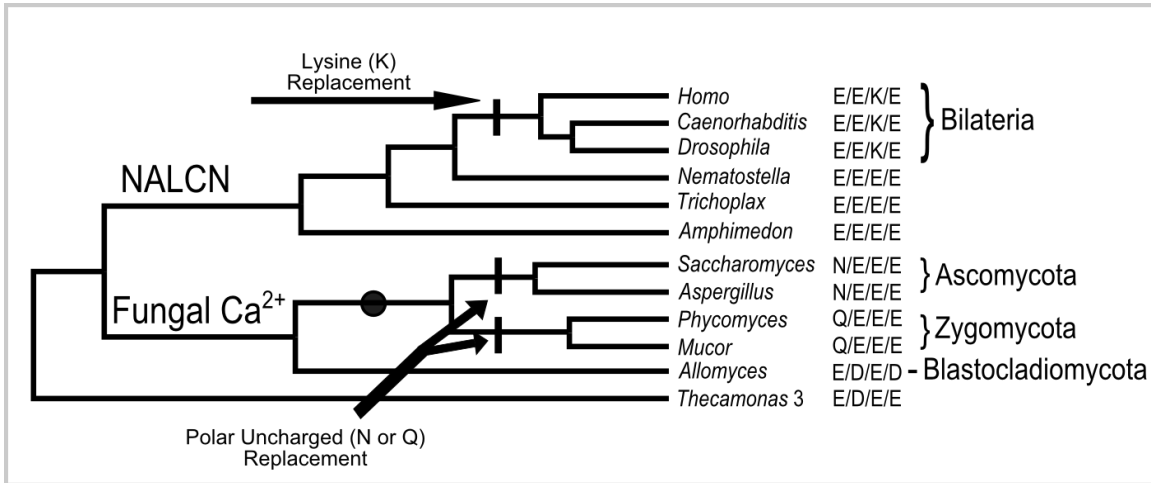

Figure 2.2: Pore states mapped onto the voltage-insensitive sub-tree.

We show two fixations for a polar, uncharged amino acid along the branches leading to ascomycetes and zygomycetes, but it is equally possible that either an asparagine (N) or a glutamine (Q) could have fixed in the common ancestor of these lineages (black circle) and changed to the other amino acid along one of the branches. Early-branching lineages have pores with acidic residues (D or E).

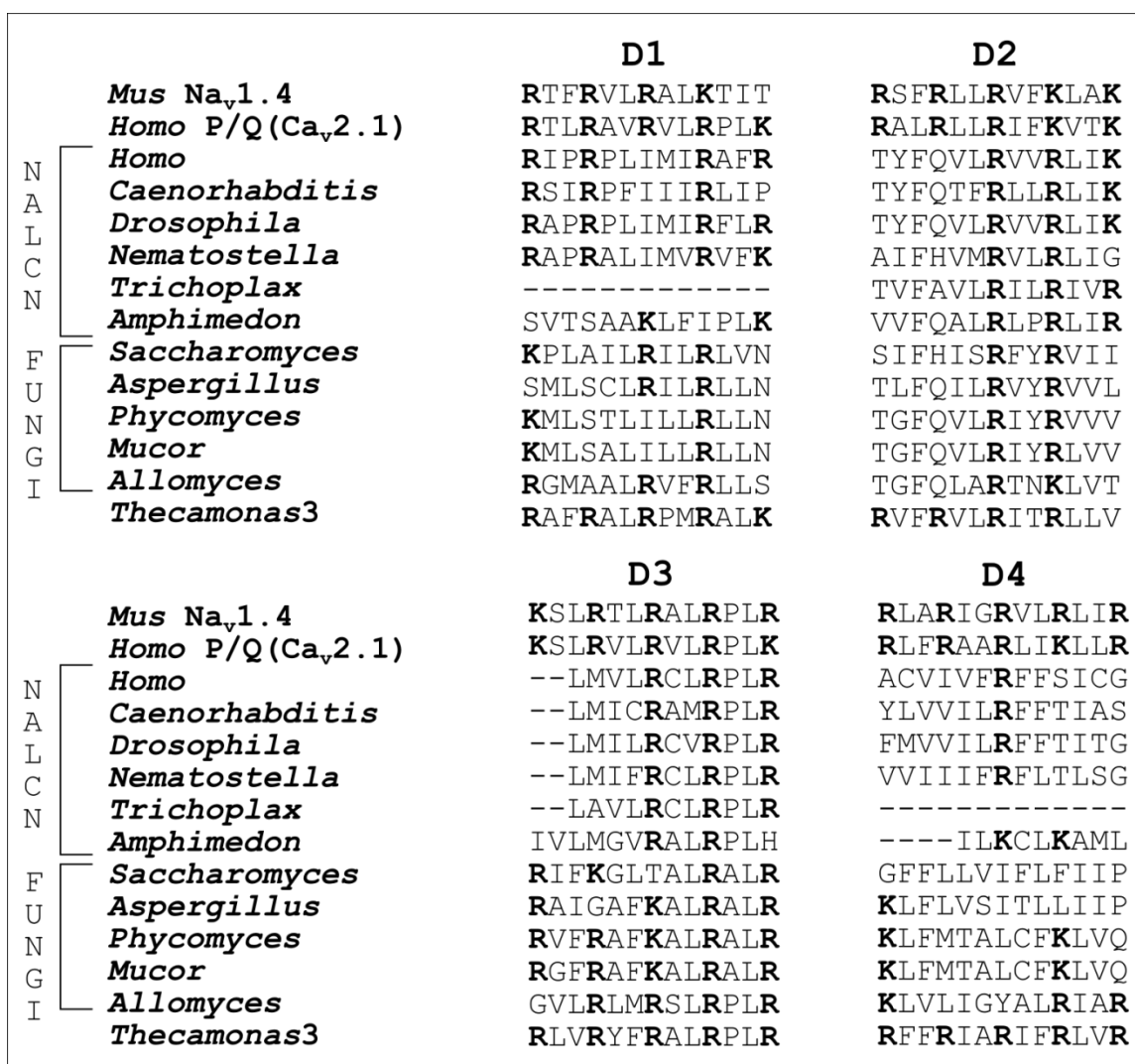

Figure 2.3: Alignment of the voltage-sensing S4 segments from four-domain ion channels.

Na_v, Ca_v, NALCN, fungal calcium channels, and an apusozoan outgroup (*Thecamonas 3*) are all shown. D1-4 are the constituent domains and the voltage sensing residues, arginine (R) or lysine (K), are in bold. NALCN and fungal channels have reduced numbers of voltage sensors relative to Na_v, Ca_v and apusozoan channels.

Chapter 3: Independent Acquisition of Sodium Selectivity in Bacterial and Animal Sodium Channels⁴

INTRODUCTION

Uni-cellular and multi-cellular organisms alike coordinate behavior with regenerative ionic currents on their cell membranes that (Bertil Hille 2001). This type of signaling system has its most complex expression in the action potentials and neural coding that occur in the excitable cells of animals.

Coordinated ion fluxes are largely carried by proteins in the super-family of voltage-gated ion channels (Bertil Hille 2001). These proteins can be single domain tetramers, two domain dimers, or a four-domain protein that comprises the whole pore-forming structure (Bertil Hille 2001). The function of the channel is largely determined by its selectivity to specific ion species and by the stimulus that opens the channels—its method of “gating.” The voltage-gated sodium (Na_v) and calcium channels (Ca_v), which drive the upstroke of action potentials and transduce electrical signals into cellular signals, respectively, have the four-domain architecture, whereas the voltage-gated potassium channels (K_v) have only one domain. Four-domain channels are hypothesized to have evolved from a single-domain channel by two rounds of internal duplication (Strong, Chandy, and Gutman 1993).

Although crystallographic studies have led to important discoveries about K_v channels, structural studies of the four-domain Na_v and Ca_v channels have not achieved the same level of precision (Sato et al. 2001), leaving the atomic details of the ion permeation and gating of these important proteins in the dark. The recent discovery of and subsequent structural work on a voltage-gated, sodium-selective, single-domain channel in bacteria (BacNa_v) was therefore greeted with excitement as a potential model

⁴ Chapter 3 has been previously published in: Liebeskind BJ, Hillis DM, Zakon HH (2013) *Current Biology* 23(21):R948–R949.

of four-domain Na_v channels (Payandeh et al. 2011; Charalambous and Wallace 2011; Ren et al. 2001).

BacNa_v channels have very different pores and domain structure than eukaryotic Na_v channels, however, and these studies often lack clear statements of homology between the two channel types (Ren et al. 2001; Payandeh et al. 2011; Charalambous and Wallace 2011), making it unclear whether the molecular correlates of function are truly comparable between animal Na_v and BacNa_v channels. BacNa_v channels are often referred to as “ancestors” of Na_v channels (Charalambous and Wallace 2011), a claim whose evolutionary meaning is difficult to interpret. We addressed this by grounding the relationships of major channel groups in an evolutionary framework, with a special focus on BacNa_v channels.

RESULTS AND DISCUSSION

Using BLAST searches of publicly available genomes, we found several surprising sequences, including: putative voltage-gated Ca_v channels in the zoosporic fungal lineages *Piromyces* (JGI protein ID: 58244) and *Gonapodya* (47550); BacNa_v-like sequences in several eukaryotic protists; and a BacNa_v homolog in the fungus *Piromyces*. The Ca_v sequences are the first Ca_v channels to be reported in fungi. Ca_v channels were thought to have been lost in fungi (Cai and Clapham 2012; Liebeskind, Hillis, and Zakon 2012), but this discovery re-dates the loss to after these early-branching fungi diverged from other fungal lineages. A set of single-domain channels that resemble BacNa_v channels were found in several protists including ciliates (*Paramecium* and *Tetrahymena*), diatoms (*Thalassiosira*), the oyster pathogen *Perkinsus*, and *Aureococcus*, an alga responsible for brown tides. The BacNa_v homolog in *Piromyces* is likely to be a horizontal gene transfer event, perhaps conferring pH sensitivity (Ito et al. 2004) or other physiological adaptations that aid the unique lifestyle of *Piromyces* in the digestive system of ruminants (Liggenstoffer et al. 2010).

The constituent domains of four-domain channels have what may be called molecular serial homology, where all four domains are equally related to the single-

domain precursor. We therefore followed the procedure of Strong *et al.* (Strong, Chandy, and Gutman 1993) and broke the four-domain channels into their constituent domains, making the smallest homologous unit (the domain) into the operational taxonomic units in the phylogeny. Figure 3.1 shows strong support for the traditional view of ion channel evolution (Strong, Chandy, and Gutman 1993), with a single origin of the four-domain structure in Na_v and Ca_v channels. DI and DIII form a clade, as do DII and DIV, in keeping with the hypothesis of two sequential round of internal gene duplication (Strong, Chandy, and Gutman 1993).

BacNa_v channels fell outside the four-domain group with strong support, rejecting the notion that BacNa_v channels can be considered Na_v channels (Payandeh et al. 2011) in the evolutionary sense. Instead, they grouped near CatSper channels, in keeping with earlier studies that showed that both BacNa_v and CatSper channels are used as pH sensors in the bacterial and sperm cells in which they are respectively expressed (Ito et al. 2004; Kirichok, Navarro, and Clapham 2006). We therefore propose that the BacNa_v, CatSper, and the novel single-domain protist types be viewed provisionally as a pH-gated group, based both on evolutionary relatedness and conservation of function.

This tree rejects the possibility of BacNa_v channels being placed within Na_v channels, but it is still possible that BacNa_v are functionally similar to the precursors of animal Na_v channels. There are two mutually exclusive hypotheses about the evolution of ion selectivity in voltage-gated ion channels. In one scenario (Fig. 3.2a), sodium selectivity is independently acquired in BacNa_v and animal Na_v channels. In the other, BacNa_v channels are similar in function to the common ancestor of all non-K_v channels, and selectivity for sodium is the ancestral state for all these channels (Fig. 3.2b).

To test these hypotheses, we used ancestral state reconstruction to estimate whether functionally characterized BacNa_v channels have the same amino acids in their ion selectivity filter as the channel ancestral to extent BacNa_v channels. This method uses an evolutionary model to reconstruct the most likely ancestral sequence for a clade given an alignment and a tree.

The insert to Figure 3.1 shows the ancestral pore reconstruction for all sampled BacNa_v channels (The full tree used for reconstruction can be found in Figure 3.3). Functionally characterized BacNa_v channels have the selectivity filter sequence LESWAS or LESWSM (Yue et al. 2002; Koishi et al. 2004). Aspartate residues (D) were more common in the ancestral pore than in characterized BacNa_v sequences. An aspartate in the sixth position, which occurs in the ancestral channel, is enough to nearly equalize the permeability to calcium and sodium in mutated channels (Yue et al. 2002). An aspartate at both the third position, which was nearly as probably as a serine in our reconstruction, and the sixth position would strongly suggest calcium selectivity in the ancestor of BacNa_v channels (Yue et al. 2002). We therefore find it most likely that the ancestor of BacNa_v channels was a non-selective, or even calcium-selective, pH-sensitive channel resembling CatSper channels in structure and function (Ito et al. 2004; Kirichok, Navarro, and Clapham 2006). Selectivity for sodium is therefore a derived trait in the channels that have been expressed and characterized.

In this study we asked whether selectivity for sodium is directly comparable in Na_v and BacNa_v channels by exploring the evolutionary history of the latter group. We found that sodium selectivity almost certainly arose independently in BacNa_v and Na_v channels, and that BacNa_v should not therefore be thought of as evolutionary precursors of animal Na_v channels. This finding does not preclude the use of BacNa_v channels as models for Na_v channel function, however. Rather, our study begins the work of placing BacNa_v channels in an integrative framework that will allow more fruitful comparisons to animal channels in the future.

METHODS

Sequence Collection

For the comparison of the major ion channel families in Figure 3.1, human genes were used as BLASTp queries against the NCBI's Reference Sequence (<http://www.ncbi.nlm.nih.gov/refseq/>), the JGI (<http://genome.jgi.doe.gov/>), and the

Origins of Multicellularity

(http://www.broadinstitute.org/annotation/genome/multicellularity_project/MultiHome.html) databases to collect sequences from the following gene families: K_v , Na_v , Ca_v (T-type, N-type, L-type), NALCN and Cch1, CatSper (subunits I-IV), CNG, TRP (NOMPC, TRPA, TRPC, TRPM, TRPML, TRPP, TRPV, Y_{vc}), TPC (TPC1, TPC2; *Canis* TPC3). The Bac Na_v channel from *Bacillus halodurans* (NaChBac) was used as a query to collect Bac Na_v homologs from diverse bacterial lineages, and to find eukaryotic homologs in the abovementioned databases.

For the ancestral state reconstruction, we desired an unbiased sampled of Bac Na_v diversity. The high rates of horizontal gene transfer among bacterial lineages make taxonomic sampling inappropriate for this end. We therefore opted to use a representative proteome database, available through the HMMER server (Chen et al. 2011; Finn, Clements, and Eddy 2011). We used the voltage-gated ion channel hidden Markov model (HMM) from PFAM (PF00520.26, accessed on Sep. 28th, 2011) (Punta et al. 2011) to search the smallest representative proteome database (rp-15), gathered all bacterial sequences above threshold, and trimmed these of channels with K_v pores (GYG). These representative proteomes contain sets of sequences that are representative of sequence diversity in the larger databases, so this is a simple and repeatable way to cover Bac Na_v channel diversity.

Alignment and Tree Reconstruction

We used GUIDANCE (Penn et al. 2010), driving MAFFT (Katoh et al. 2005), to estimate the uncertainty of global alignments due to poorly supported guide tree estimation. The alignment was very unstable, and retaining only columns above GUIDANCE's default threshold yielded a very sparse alignment. We therefore chose to align the sequences to the HMM above using hmalign, which is distributed with HMMER (<http://hmmer.org/>). This produced well-supported alignments, as judged by the posterior probabilities output by hmalign. These alignments were stripped of non-homologous regions (--trim option in hmalign) and then pruned of columns that were

majority gapped on the GapStreeze server (Los Alamos HIV Sequence Database: <http://www.hiv.lanl.gov/content/sequence/GAPSTREEZE/gap.html>).

We found that most of the channel types, including TRP, TPC, and NALCN-type channels, could not be reliably placed within the phylogeny, and they were excluded from the analysis. These channels are functionally diverse relative to the typical voltage-gated types, and this may have led to more extreme sequence divergence. CNG channels were always found to be a sister group to K_v channels, and were also excluded for clarity. Two $BacNa_v$ channels were highly divergent and were also excluded. These exclusions did not change the conclusions of our analyses, only their support.

The trees in Figures 3.1 and 3.3 were estimated in Mr. Bayes under the WAG+G+F model (Huelsenbeck and Ronquist 2001; Whelan and Goldman 2001). We used two independent runs with four chains each in MCMC simulations, and ran them for 6×10^6 and 2×10^6 generations, respectively. To test for proper run convergence and mixing, we used Tracer (Rambaut and Drummond) to estimate effective sample sizes and verify parameter mixing, and AWTY (Nylander et al. 2008) to test for topology convergence. Both analyses achieved combined effective sample sizes greater than 200 and showed good topological convergence. Ten independent replicates in Garli (Zwickl 2006) under a slightly better fit model, LG+G+F (Le and Gascuel 2008), yielded very similar results (not shown).

There was a high level of uncertainty in the distal branches the phylogeny of $BacNa_v$ channels in Figure 3.3. In addition, analyses in Prottest found that LG+G+F, which is not implemented in Mr. Bayes, was the also the best fit model of evolution for the dataset used in Figure 2, with WAG+G+F as the second best. Since model choice is likely to affect ancestral state reconstruction, we estimated trees under Maximum Likelihood in Garli under this model for the ancestral state reconstruction analyses. To get a good sampling of the topological uncertainty, we ran ten independent replicates of Garli. The best tree was found four out of the ten times. We used Lazarus (Hanson-Smith, Kolaczkowski, and Thornton 2010; Z. Yang 2007) to estimate the ancestral states

of the BacNa_v clade on the seven unique topologies, using the LG+G+F model. Lazarus also estimates a maximum *a posteriori* ancestral state reconstruction, which we report in Figure 3.3, with the heights of the pore states in proportion to their posterior probability. The estimates were quite robust despite the topological uncertainty, in concordance with earlier findings (Hanson-Smith, Kolaczkowski, and Thornton 2010). Several of the analyses above relied heavily on the Python libraries Biopython (Cock et al. 2009) and Dendropy (Sukumaran and Holder 2010).

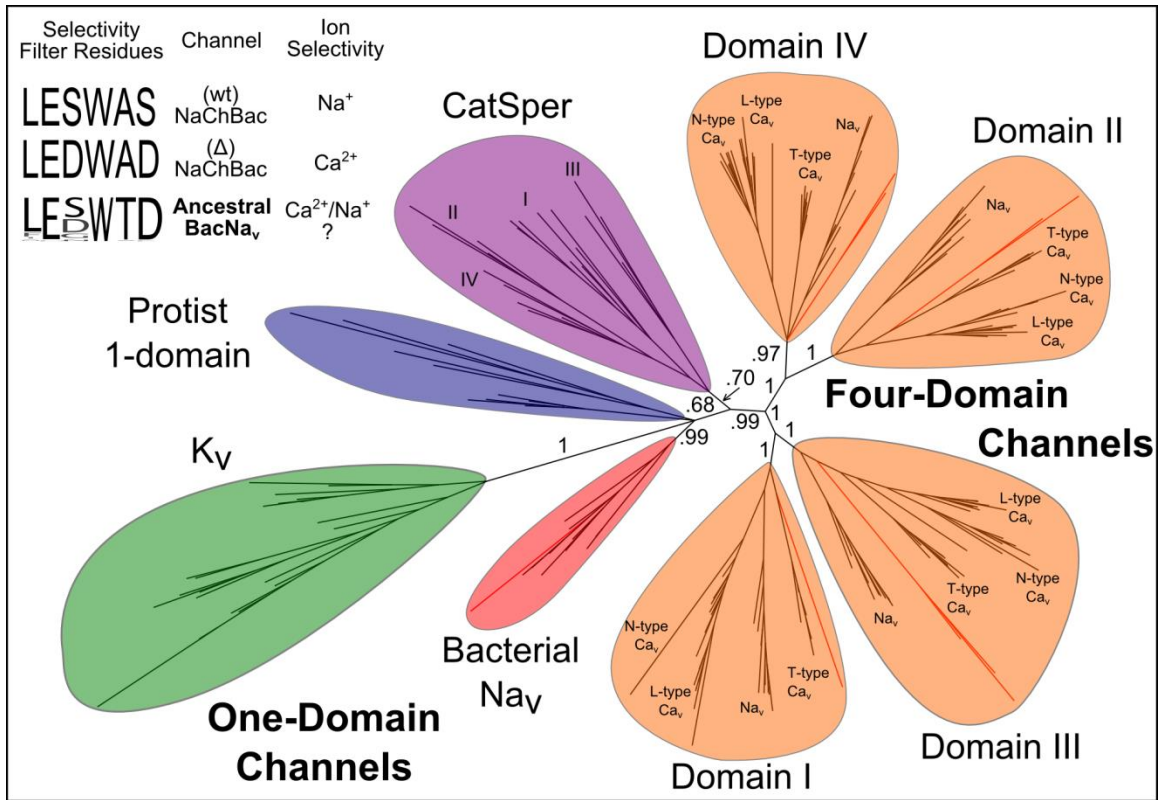

Figure 3.1: Unrooted tree of major ion channel types and ancestral state reconstruction of BaNa_v selectivity filter.

The four homologous domains of Ca_v and Na_v channels have a single, well-supported origin to the exclusion of all the single-domain channels. The branching order of CatSper, BacNa_v, and eukaryotic single-domain channels is not well supported, but we do not find BacNa_v near eukaryotic Na_v channels in any scenario. Novel sequences include a clade of one-domain channels in protists, and channels from early-branching zoosporic fungi (red lineages), including a horizontally transferred BacNa_v channel and the first described Ca_v channels in fungi. Bayesian posterior probabilities are provided for interior branches. Ancestral states for the BacNa_v family's selectivity filter are displayed in proportion to their *a posteriori* likelihood. The wild-type selectivity filter for the founding member of the BacNa_v family, NaChBac, and a mutant channel with Ca²⁺ selectivity (Yue et al. 2002) are displayed for comparison. The ancestral pore is more similar to the calcium selective mutant.

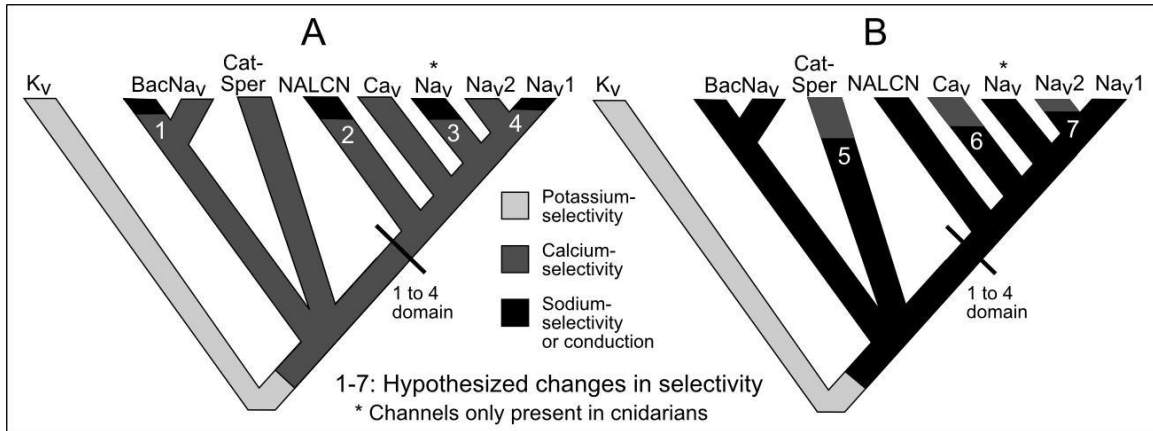

Figure 3.2: Two models of the evolution of ion selectivity in the voltage-gated ion channel superfamily.

(A) The traditional view: Selectivity for sodium is acquired independently in BacNav_v channels and animal Nav_v channels. NALCN channels also independently acquired sodium permeability but are not highly selective (Ren 2011). (B) BacNav_v channels function like the precursors of all the non-K_v channels. Calcium selectivity is therefore independently acquired in several lineages. Our ancestral state reconstruction supports a change to sodium selectivity in one BacNav_v lineage (1), and makes a late acquisition of calcium selectivity in CatSper channels unlikely (5), supporting hypothesis (A). Further references can be found that support or reject the changes in ion selectivity implied in the two hypotheses: **(2)** (Liebeskind, Hillis, and Zakon 2012; Senatore et al. 2013); **(3,4, and 7)** (Liebeskind, Hillis, and Zakon 2011; Gur Barzilai et al. 2012); **(6)** (Verret et al. 2010; Hille 2001).

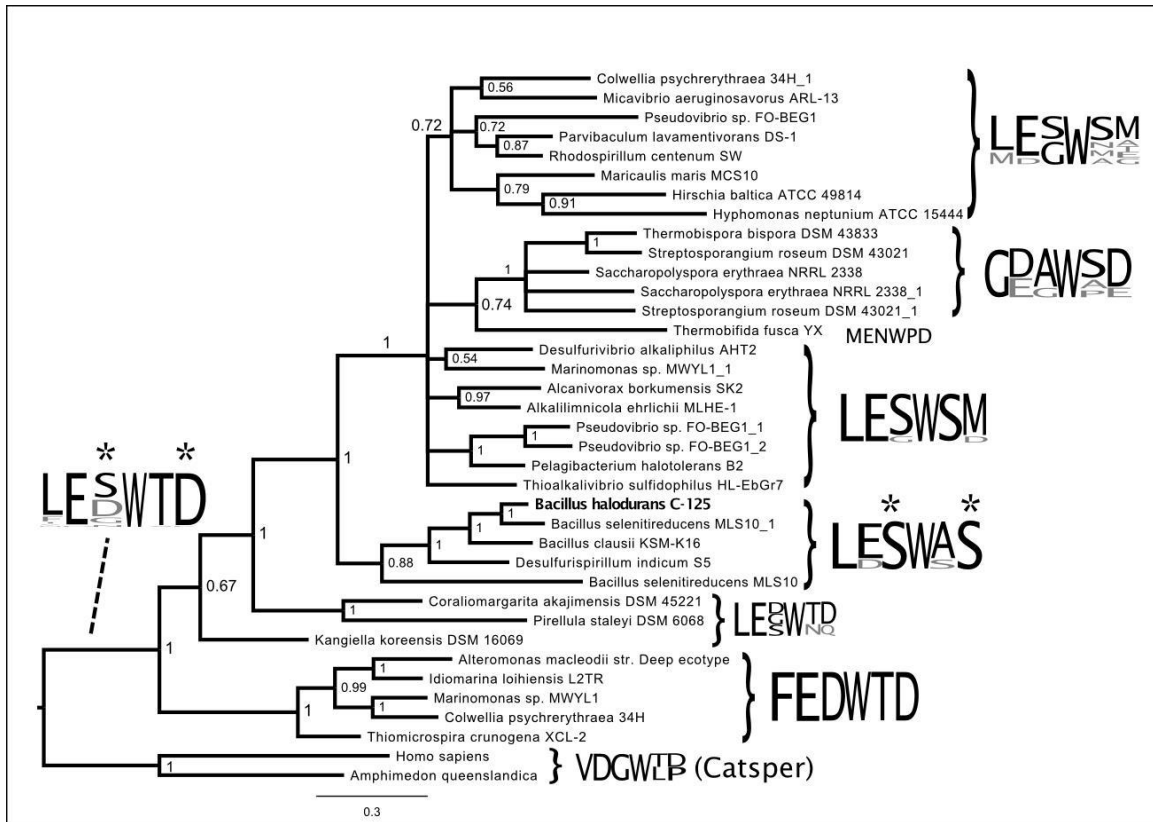

Figure 3.3: Phylogeny of the BacNa_v family and ancestral state reconstructions of selectivity filters.

Bayesian posterior probabilities are reported for all bipartitions. The founding member, NaChBac from *Bacillus halodurans*, is bolded. Pore states are reported next to clades with the heights of the residues in proportion to their frequency. The maximum *a posteriori* estimate of the ancestral pore is labeled with residue heights in proportion to their probability. Stars are placed over sites in the pore that, when changed to an aspartate, caused a significant shift towards calcium selectivity in NaChBac (Yue et al. 2002). The ancestor has aspartates at the sixth position with high probability and at the third position with a similar probability to serine. An aspartate in the sixth position caused calcium block in NaChBac, a hallmark of calcium channels. Aspartates in both positions caused BacNa_v channels to be more selective for calcium than sodium (Yue et al. 2002; Shaya et al. 2011).

Chapter 4: Convergent Evolution of Ion Channel Genome Content in Early Animal Evolution⁵

INTRODUCTION

Animal nervous systems are complex cellular networks that encode internal states and behavioral output. They achieve this complexity primarily in two ways. First, nervous systems encode information in a wiring scheme whose connections differ in strength and sign (excitatory or inhibitory). The strengths can often change in an activity dependent fashion (Bullock and Horridge 1965). Second, nervous systems have a dynamic neural code made up of all-or-none action potentials and subtler graded potentials (Bishop 1956). The shape, timing, and duration of evoked electrical potentials vary greatly among and even within neurons, and can also be activity dependent. These two types of complex signaling, respectively among and within cells, are the fundamental work of nervous systems (Bullock and Horridge 1965) and they are made possible by the great variety of ion channel proteins expressed in neurons.

Recent studies have found that most ion channels and proteins involved in the formation of synapses are ancient, having evolved long before the origins of nervous systems or even of animal multicellularity (Burkhardt et al. 2011; Cai and Clapham 2012; Chiu et al. 1999; Liebeskind, Hillis, and Zakon 2011; Sakarya et al. 2007). But the nature of the first animals and of the cells from which nervous systems evolved are not well understood, though many theories exist (Jekely et al. 2008; Nielsen 2008; Pantin 1952; Passano 1963), and little is known about the genomic events that facilitated the rise of complex nervous systems. New information about animal phylogeny has demanded a return to these old questions concerning the nature of the first animals and the evolutionary history of nervous systems (Dunn et al. 2008; Ryan et al. 2013; Ryan 2014; Moroz et al. 2014).

⁵ Chapter 5 is in review: Liebeskind BJ, Hillis DM, Zakon HH (2014) PNAS.

This new information concerns the placement of the ctenophores, or comb jellies. Recent studies place ctenophores as the sister group to all other metazoans, a surprising finding given that ctenophores are complex predators with fairly sophisticated nervous systems (Moroz et al. 2014). In contrast, sponges, which traditionally were considered to be the sister-group of the remaining animals (Philippe et al. 2009), do not have nervous systems (but see (Leys, Mackie, and Meech 1999)). Recent genomic analyses have found that ctenophores are lacking many nervous system and muscle-associated genes, suggesting independent origins of these structures in ctenophores (Steinmetz et al. 2012; Moroz et al. 2014; Moroz 2009). These findings have revived the debate about whether animal nervous systems have one or more origins (Ryan 2014; Moroz 2009).

Many studies have addressed the origin of animal nervous systems using comparative physiological, developmental, or morphological evidence (Arendt et al. 2008; Holland et al. 2013; Watanabe, Fujisawa, and Holstein 2009). We used a different technique: ancestral gene content reconstruction. This approach has been used to explore the origin of multicellularity (Richter and King 2013), the evolution of prokaryotic metabolism (Boussau et al. 2004), and the expansion of G protein-coupled receptors in animals (Sakarya, Kosik, and Oakley 2008). Gene duplication has long been known to be a major source of novelty and complexity (Ohno 1970), and many of the families we analyzed play few known roles outside of nervous systems. We therefore hypothesized that the elaboration of nervous systems coincided with an expansion of the ion channel families that are expressed there. We employed two methods (Sakarya, Kosik, and Oakley 2008; Chen, Durand, and Farach-Colton 2000) to reconstruct the ancestral copy number for a variety of ion channel families, and tracked the evolution of gene duplications across the animal and fungal tree. The evolution of some of these families have been studied by other groups (Gur Barzilai et al. 2012; Jegla et al. 2012; Moroz et al. 2014; Sakarya, Kosik, and Oakley 2008), but here we combine current methods of ancestral genome content reconstruction with dense sampling of early-branching species

and gene families to search for patterns of gene duplication that might illuminate the early history of nervous systems.

RESULTS

Large Scale Patterns of Gene Gain and Loss

We used a custom bioinformatics pipeline to collect and annotate predicted proteins from 16 ion channel families (Table 4.1) for 41 broadly sampled opisthokonts (the group that includes animals, fungi, and related protists), and an apusozoan outgroup. The ion channel families we analyzed play diverse roles in nervous systems (Table 4.1). Some families, such as the voltage-gated families, are almost solely associated with nervous system function in animals, while others, such as P2X receptors, play more diverse roles, with only some isoforms being expressed in nervous systems. This dataset was then used to infer ancestral genome content and the timing of gene duplications using EvolMap (Sakarya, Kosik, and Oakley 2008).

Consistent with previous literature (Cai and Clapham 2012; Chiu et al. 1999; Liebeskind, Hillis, and Zakon 2011; Moroz et al. 2014), we found that these gene families are ancient, with all but two (LIC, ASC) being found in the most recent common ancestor of the taxa examined here. Only the ASC family was found to be metazoan specific. We then pooled all the families together and plotted net gains and percent losses on the species tree, represented as branch lengths (Figure 4.1). The animal lineage has been dominated by gains and the fungal lineage by losses. These patterns are not without exception, however: two major loss events occurred in the common ancestors of deuterostomes and ecdysozoans (Figure 4.1). Both loss events occurred just before major gene family expansions. We also found that the peripheral branches (near the tips) were especially enriched for gene duplications, suggesting multiple independent rounds of gene duplication among the taxa examined.

Convergent Evolution of Gene Content in Animal Nervous Systems

To tease apart the role of the different gene families in these broad-scale patterns, we inferred ancestral gene content and the phylogenetic pattern of gain and loss for each of the 16 ion channel families separately. Counts for key internal nodes are shown on the animal subtree in Figure 4.2. We observed large expansions of the LIC, GIC, and K_v families at several places on the tree. These gene family expansions happened independently in the most recent common ancestors (MRCA) of bilaterians, vertebrates and cnidarians. The vertebrate gene family expansions occurred after the loss event in the MRCA of deuterostomes (Figs. 4.1- 4.3). This loss event involved reductions in several families, with the largest families, such as LIC, having the largest losses (Fig. 4.3). The MRCA of ctenophores underwent an expansion resembling the expansions in bilaterians and cnidarians, but the LIC family was lost in ctenophores. No expansions were seen in the branches leading to the MRCA of cnidarians plus bilaterians, or in the MRCA of animals – two places where nervous systems have been hypothesized to have evolved (Ryan et al. 2013; Ryan 2014; Moroz et al. 2014; Moroz 2009; Dunn et al. 2008).

Ecdysozoans and lophotrochozoans also had large expansions of LIC, GIC, and K_v channels, but also had huge expansions of the ASC family (Fig. 4.4). These expansions happened mostly in the terminal lineages leading to each species (Fig. 4.1). Figure 4.4a shows ion channel family counts from representative species from each major lineage represented in Figure 4.2. All taxa with nervous systems, with the notable exception of the tunicate *Ciona*, were enriched for similar gene families. The two taxa without nervous systems, *Trichoplax* and *Amphimedon*, had smaller ion channel complements. The MRCAs of chordates, cnidarians plus bilaterians, and animals each had ion channel complements that resembled extant animals without nervous systems more than animals with nervous systems.

To visualize the genomic complements for all channels at all tips, we used principal components analysis (PCA) to reduce the 16 original dimensions (counts for each ion channel family) into the first two principal components (PCs) (Fig. 4.4c). PCA

transforms high dimensional data into new variables, the PCs, which are linear combinations of the original variables and are ordered by how much of the variance they explain. Proximity in the space of the first two PCs represents similar gene content distributions. Figure 4.4c shows the normalized gene contents plotted in the space of the first two principal components and the loadings of each gene on these two axes. We also plot the ion channel loadings, which show how the abundance of each channel family correlates with the PCs. Thus dots that cluster near arrows represent genomes with a high relative content of that ion channel type.

We found that the genome contents of the major lineages were distinguished from each other on the PCA (Fig. 4.4c). The first principal component primarily distinguished fungi, which were dominated by the Leak (Cch1) and CIC families and had lost most of the other types, from animals, which mostly had all the gene families. Fungi with a swimming zoospore, however, tended to have more channel types, including Ca_v channels (Liebeskind, Hillis, and Zakon 2013). The second principal component separated genomes with a higher content of the Ca^{2+} channel families RyR and TPC from those that had more voltage-gated types, primarily K_v . Most genomes that were dominated by Ca^{2+} channels were from protists.

Animal genomes have a relatively high proportion of synaptic (GIC, LIC, ASC) and voltage-gated channel types (Na_v , K_v). These are the gene families in our dataset most closely associated with nervous system function. Genomes of animals with nervous systems clustered together to the exclusion of the two animals lacking nervous systems: the sponge *Amphimedon* and the placozoan *Trichoplax*. These two animals clustered closer to protists due to a larger proportion of Ca^{2+} channels. The tunicate *Ciona* was again an interesting exception. *Ciona* branched from the deuterostome lineage after the major loss event and before the major bout of gene duplication in the ancestor of vertebrates (Figs. 4.1, 4.2). Hence it clustered closer to protists and animals without nervous systems.

The MRCAs of chordates, cnidarians plus bilaterians, and all animals grouped more closely to sponges, placozoans, and protists than to any extant animal with a nervous system. This suggests independent gene family expansions of the ion channel that were enriched in extant animals with nervous systems. From these three ancestral points in the lower left quadrant, which is characterized by a relatively high proportion of calcium channels (TPC, Ca_v s), the ctenophores, cnidarians, and bilaterians independently evolved similar genome contents that caused them to cluster in the lower right quadrant, which is characterized by a high proportion of synaptic ion channel (ASC, GIC, LIC) and voltage-gated types (K_v and Na_v) (Fig. 4.4c).

Ancestral Reconstructions are Insensitive to Reconstruction Method

The analyses reported above relied on ancestral gene counts inferred with EvolMap (Sakarya, Kosik, and Oakley 2008), which uses pairwise alignment scores, but not full gene trees. The reasons for choosing EvolMap for the main analyses are discussed below (*Methods*). We also inferred consensus gene trees using 100 bootstrap replicates in RAxML (Stamatakis 2006) and inferred ancestral genome content using gene tree/species tree reconciliation based on parsimony in the package Notung (Chen, Durand, and Farach-Colton 2000). Overall bootstrap support was poor, but reconciliation using the consensus trees recapitulated the EvolMap results, despite using a different method and a different dataset (*Methods*). In particular, the large gene family expansions in the MRCAs of vertebrates, cnidarians, and ctenophores are still found. The smaller expansion in the MRCA of bilaterians was not as clear, however, nor was the loss event in the MRCA of ecdysozoans. These smaller events are probably not visible because of erroneous overestimates of ancestral genome content (Hahn 2007). Similar results were found when maximum likelihood trees were used instead of consensus trees (not shown). Thus, even though there was uncertainty in our tree inference, topologies that would result in reconstructions that differ substantially from the EvolMap analysis were not favored. Our results are therefore robust to the method used to infer ancestral genome content.

Findings Extend to Other Nervous System Genes

We wondered whether the general patterns found in ion channels extended to other genes, including those not associated with nervous systems. We therefore tested the three main classes of G protein-coupled receptors (GPCRs), which are closely associated with nervous systems, Actin, which is not specific to nervous systems but may correlate with muscular complexity (Steinmetz et al. 2012), and two protein domains not strongly associated with neuro-muscular function: ubiquitin, and DNA polymerase family A (polA). We found that the patterns of gain and loss in GPCRs were roughly similar to the ion channels, and that the patterns in ubiquitin and polA were not (Fig 4.5). Remarkably, GPCRs underwent the same loss event in the common ancestor of deuterostomes followed by a gain in the common ancestor of vertebrates. These gain and loss events were not observed in ubiquitin and polA and were only weakly present in actin, which functions in the musculature and may therefore correlate with nervous system complexity. This suggests that the pattern of gain and loss is specific to nervous system-associated genes.

Choice of Species Tree

The radiation of the major animal lineages was ancient and probably quite rapid. This situation makes the inference of branching order very difficult (Rokas, Krüger, and Carroll 2005; Philippe et al. 2011). To see if there was any evidence for a certain species tree in our gene duplication data, we explored which species tree allowed the most parsimonious reconciliations with our gene trees. We tested all 15 resolutions of the four-way polytomy between *Amphimedon*, *Trichoplax*, ctenophores (*Mnemiopsis*, and *Pleurobrachia*), and cnidarians + bilaterians, as well as the topology found by Philippe *et al.* (Philippe et al. 2009) that places ctenophores and cnidarians together, with sponges branching first, followed by *Trichoplax*. We refer to this tree as the Coelenterata hypothesis. PAUP was used to generate the 15 resolved species trees from the polytomy (Swofford, David L. 2003). We then reconciled the 16 topologies with each of our 16 ML gene trees using Notung, and counted up the total gene duplication/loss costs for each

species tree using Notung's default rooting method. On the principal of parsimony, the correct species tree would be the one with the lowest incurred cost.

We found that no one tree was clearly favored over the others (Fig. 4.6). Generally, trees with ctenophores near the base were favored. The best tree had ctenophores as the earliest-branching lineage, but grouped sponges and placozoans as a monophyletic clade, which has never been found in the major phylogenomic studies. The Coelenterata hypothesis, however, was strongly disfavored. Because of these considerations, we used a topology that reflects a growing consensus around early metazoan relationships, with ctenophores branching first, followed by sponges, placozoans, cnidarians, and then bilaterians (Dunn et al. 2008; Hejnol et al. 2009; Ryan et al. 2013; Moroz et al. 2014). The finding that several species trees are roughly equivalent in terms of duplication/loss costs also has the effect of showing that our results are not heavily dependent on the species tree topology.

DISCUSSION

We have shown that the major lineages of animals with nervous systems have acquired similar ion channel complements via convergent gene family expansions. The gene families that underwent the greatest expansions were two synaptic ion channels types, the Cys-loop receptors (LIC) and the glutamate-gated channels (GIC), as well as acid-sensing channels (ASC), and the voltage-gated potassium channels (K_v). The LIC family was lost in ctenophores, however. Recent evidence suggests that ASCs play a role in synaptic transmission and associative learning (Wemmie et al. 2002). Moroz has suggested that these genes are key neurotransmitter receptors in ctenophores (Moroz et al. 2014). Perhaps ASCs fill some of the roles that LICs do in other organisms. Early-branching lineages such as ctenophores may therefore be good model systems to explore these understudied channels.

Surprisingly, the major expansions we observed did not occur on any of the nodes where nervous systems are currently hypothesized to have evolved (Fig. 4.2). Rather, they occurred much later in the common ancestors of vertebrates, bilaterians, cnidarians,

and ctenophores, and also within the individual lineages of protostomes (Figs. 4.1 – 4.3). The animal stem lineage, from the MRCA of all animals to the MRCA of cnidarians plus bilaterians, experienced very little change in ion channel genome content, and this content did not differ substantially from the unicellular ancestor of animals and choanoflagellates (Fig. 4.2). The simplest explanation for this pattern is that nervous systems originated early, were very rudimentary for a long period, and then convergently evolved in complexity by relying on duplications of similar channel types. Another explanation is that stem animals employed nervous system-associated genes in proto-nervous tissues to mediate simple behaviors, as is likely the case in *Trichoplax* or phototactic sponge larvae (Leys and Degnan 2001; Jekely et al. 2008), and extant nervous systems were derived independently from these excitable but non-neural tissue types (Mackie 1990; Moroz 2009). Regardless of which scenario is true, our findings suggest a very large role for convergence in extant animal nervous systems. A particularly striking feature of this convergence is the similarity between extant taxa in the relative abundances of the different ion channel families that underwent the largest expansions (Figs 4.2, 4.4c).

A large repertoire of synaptic channels may have helped nervous systems encode more complex behaviors by facilitating neuronal connections of differing strengths, sign, and context dependent activity. K_v channels shape action potentials and spike trains, so an expansion of this family may have enabled a dynamic electrical code. This combination of electrical and network complexity is a hallmark of complex nervous systems. Gene family expansions of channel types associated with these two types of complexity may therefore be a genomic signature for increasing nervous system complexity, a signature which we found to occur at several places in the animal phylogeny.

This study may therefore help explain the distribution of nervous system complexity across the animal tree. In an early attempt to synthesize comparative electrophysiological data and evolutionary theory, Bishop remarked of the phylogenetic

distribution of nervous system characteristics, that animals “seem to have available most of the tricks of functioning that any of them employ. Some other factor than availability determines the overall pattern” (Bishop 1956). This observation, though true, contrasts with the fact that animals with nervous systems do not form a monophyletic group (Dunn et al. 2008; Ryan et al. 2013; Moroz et al. 2014), nor do animals with highly complex, centralized nervous systems (Moroz 2009). We suggest that the ancient origin and independent expansions of the ion channel types explored here has helped determine this seemingly contradictory pattern. The ancient origins help explain why nervous systems employ similar genes in similar roles, and the independent expansions explain why, for instance, neurons and circuits in vertebrates, protostomes, and non-bilaterian invertebrates have such different morphologies (Mackie 1990; Bullock and Horridge 1965).

Ion channel gene expansion has not been monotonic throughout animal evolution. There were two major loss events in the ancestors of deuterostomes and ecdysozoans (Figs. 4.1 – 4.3). The deuterostome loss events caused the MRCA of chordates and the extant animal *Ciona* to seem to “revert” to more protist-like genomes (Figs. 4.4a, 4.4c). Both loss events were immediately followed by bouts of gene expansions, suggesting the possibility of genomic revolutions where loss events “clear the deck” for a period of increasing complexity and perhaps innovation.

The evolution of animal nervous systems is therefore more complex than has been appreciated. Our results suggest repeated bouts of elaboration and simplification of nervous systems that correlated with expansions and contractions of ion channels (Figs. 4.1 – 4.4) and GPCRs (Fig. 4.5). The shifts in ion channel gene content are largely captured by the second principal component of Figure 4.4c, meaning that animal genomes have fluctuated between a higher relative content of Ca^{2+} -channels (TPC, RyR, Ca_v) and a higher relative content of other voltage-gated types (Na_v , K_v) and synaptic channels (LIC, GIC, ASC). A switch from Ca^{2+} -based intracellular signaling, which all eukaryotes employ, to complex electrical signaling between cells has long been

understood as a key animal innovation (Bertil Hille 1989; Cai and Clapham 2012). Our results suggest that this was not a single evolutionary transition, but that these two types of signaling represent alternate stable states of animal complexity.

Our results are consistent with recent evidence that striated muscle evolved independently in multiple lineages (Steinmetz et al. 2012) and that ctenophores lack many neurotransmitters associated with vertebrate nervous systems (Moroz et al. 2014). Some studies have already begun to biophysically characterize the expansions of K_v channels and Na_v channels in cnidarians and relate them to their homologs in vertebrates, which evolved convergently (Jegla et al. 2012; Martinson et al. 2014; Gur Barzilai et al. 2012). Investigators have found striking similarities between these channels and those of vertebrates, despite their independent origins. Further study of the biophysical details of genome evolution in animals will help clarify the parallel origins of nervous system functions.

METHODS

Protein Sequences

Protein sequences were collected from proteomes obtained from JGI's MycoCosm (<http://genome.jgi.doe.gov/programs/fungi/index.jsf>), The Origins of Multicellularity (http://www.broadinstitute.org/annotation/genome/multicellularity_project/MultiHome.html), Ensembl (<http://www.ensembl.org/index.html>), the Ctenophore genome project websites provided by the Baxevanis and Moroz laboratories (<http://research.nhgri.nih.gov/mnemiopsis/>; <http://neurobase.rc.ufl.edu/pleurobrachia>), and the Matz laboratory website (http://www.bio.utexas.edu/research/matz_lab/matzlab/Data.html). Only proteomes that had protein-locus information were used to avoid redundancy, and only the longest isoform was used for each gene. We then used a three step process to collect and hand-annotate the data used for all subsequent analyses. We used appropriate hidden Markov models for each protein to search proteomes from each organism using the *hmmsearch*

algorithm in the HMMER package (Eddy 1998). All families had unique HMMs except for the voltage-gated channel superfamily, which includes the families K_v , Na_v , Ca_v , Leak, TPC, TRP, Slo, and CNG/HCN. All hits with a *hmmsearch* e-value below 1×10^{-2} were then searched against the Uniprot protein database using Blastp (Altschul et al. 1990) and hand-annotated.

GPCRs, and proteins containing actin, polA, and ubiquitin domains were not reciprocally blasted against Uniprot, but rather were reciprocally searched against PFAM using *hmmscan*. Only proteins hitting the desired domain with an e-value below 1×10^{-4} were retained. Proteins from the voltage-gated superfamily were first sorted into families before Uniprot annotation by annotating against the Transporter and Channels Data Base (Saier, Tran, and Barabote 2006) using Blastp. Both of these Blast analyses used 1×10^{-2} as an e-value threshold and discarded any sequences with no hit below this threshold. The final result was a hand annotated set of protein sequences for each of the 16 channel families, the GPCRs, and other protein families.

These sequences were then quality filtered by first aligning each family using the *e-ins-i* algorithm in Mafft (Katoh et al. 2005), and then searching for sequences that differed by only one aligned position or less (i.e., not just gaps). If such similar groups were found, only the longest protein sequence was retained. This was the final dataset used for EvolMap analysis, and should represent a conservative estimate of the copy number for each species.

Ancestral Genome Reconstruction

We used two different methods to reconstruct ancestral genome content. These two methods employ very different techniques, so the results consistent between the two methods should be robust to any biases unique to each method. The two different methods, their potential biases, and the way that these biases were offset by the other analysis will be briefly discussed here.

The first method, implemented in the software EvolMap (Sakarya, Kosik, and Oakley 2008), was used for all the main figures because it has fewer known biases.

EvolMap uses Blast to identify putative orthologous groups, and then creates sparse matrices of within-group pairwise alignment scores based on Needleman-Wunsch alignments. This information is then used to identify symmetrical best hits and create estimates for ancestral genome size in a post-order trace of a supplied species tree. Then the tree is traversed in pre-order, and gains and losses are inferred using Dollo parsimony. EvolMap outputs information on ancestral gene copy number, and number of gains and losses for each node. For Figure 4.1, all channel types were pooled together. To create the data for the other figures, each ion channel family was analyzed by EvolMap separately, and copy number information was collected into genome-by-family matrices using custom scripts. One potential bias in this analysis is that all proteins that passed the hand-annotation and trimming steps were kept, many of which were partial. These partial sequences may have had poor Needleman-Wunsch alignment scores and therefore have been incorrectly characterized as evolutionary novelties in proximal branches. This bias was dealt with in the second analysis by discarding short sequences.

The second method we used was parsimony-based gene tree/species tree reconciliation implemented in Notung (Chen, Durand, and Farach-Colton 2000). Each ion channel family was aligned using the *e-ins-i* algorithm in MAFFT. The original dataset had many partial sequences, as discussed above. This first alignment was used to discard sequences by first trimming columns that were over 50 percent gapped using Trimal (Capella-Gutiérrez, Silla-Martínez, and Gabaldón 2009), and then flagging sequences that had fewer than 150 amino acids in the trimmed alignments. These sequences were then removed from the unaligned data, and all families were realigned and trimmed in the same fashion. These alignments were then used for phylogenetic tree inference using RAxML (Stamatakis 2006), under the LG + CAT model (Lartillot and Philippe 2004; Le and Gascuel 2008) with the rapid bootstrap and ML tree reconstruction algorithm. The maximum likelihood trees were then used for species tree reconciliation. The unrooted gene trees were reconciled using the rooting algorithm in Notung, which finds the rooting point that minimizes gene gains and losses across the species tree, and

then outputs information on the number of gains and losses for each branch. We used custom scripts to parse the Notung output and create data matrices of ancestral node counts.

Parsimony-based gene tree/species tree reconciliation is well known to have biases that result from incorrect gene tree inference. Misplaced taxa can artificially inflate the estimates of ancestral genome sizes (Hahn 2007). This bias, however, is not expected to affect the EvolMap analysis. We also note that this bias would tend to lead to the conclusion opposite to ours because the bias artificially inflates ancestral genome size and puts many losses on terminal branches, whereas we find small ancestral genomes and many duplications on terminal branches. Thus, although this bias is present in our Notung analysis (note that ancestral genomes reconstructed by Notung are larger than those reconstructed by EvolMap, despite the fact that some sequences were removed from the Notung analysis), our conclusions are robust with respect to the method used for analysis.

Principal Components Analysis

We used normalized gene content matrices for the PCA. Each row of the matrix corresponded to one genome, extant or ancestral, and each column to a gene family. The entries were therefore the number of each ion channel type normalized by the total number of ion channels present in each genome. The matrix was then centered and scaled using the *scale* method in the standard R package. The PCA was performed in R using the method *prcomp* and visualized with the package *ggbiplot* (R Development Core Team 2008; Vu 2011).

Program Availability

All scripts used for the analysis are available on Github (<https://github.com/bliebeskind>). The programs used for parsing relied heavily on the python packages *pandas*, *dendropy*, and *BioPython* (Cock et al. 2009; McKinney 2013; Sukumaran and Holder 2010).

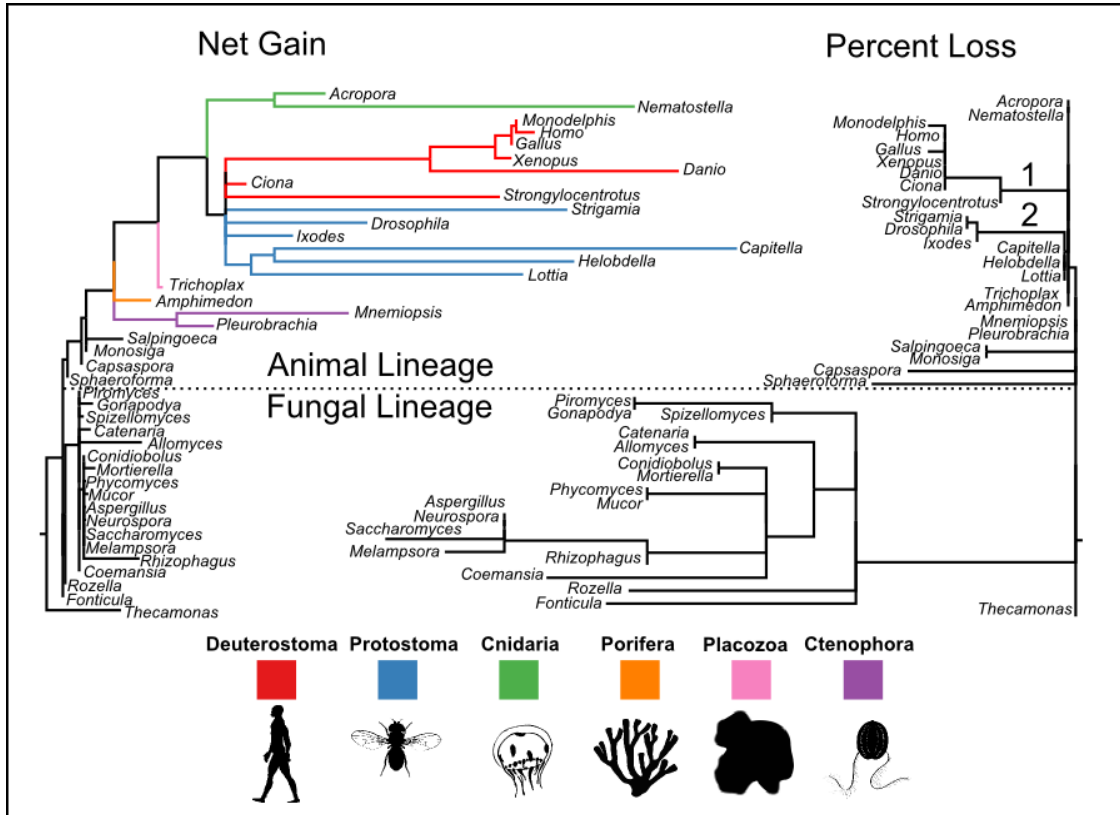

Figure 4.1: Gain and loss of ion channel families in opisthokont evolution.

The two trees have identical topologies. The branch lengths of the tree on the left are the net gain (gains minus losses). The branch lengths of the tree on the right represent percent loss (losses minus gains as a percentage of parent copy number). Two branches in animals that had large loss events are labeled: the common ancestors of deuterostomes (1) and of ecdysozoans (2).

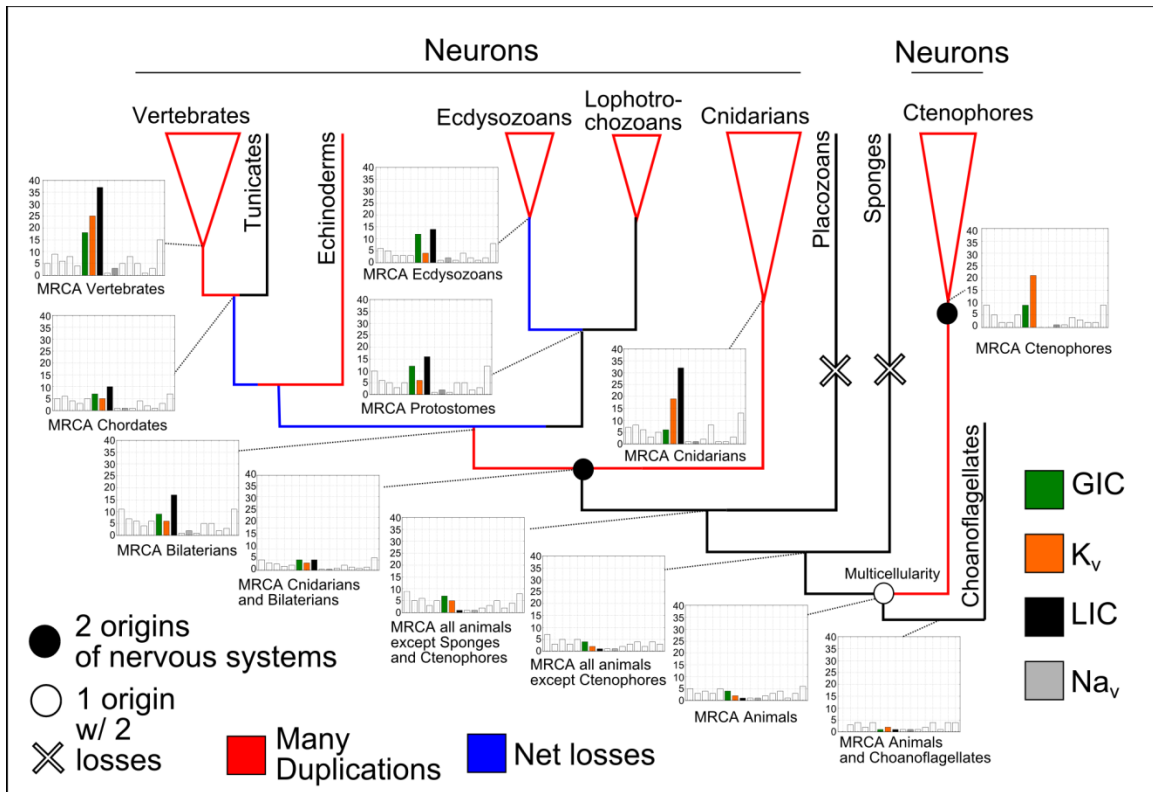

Figure 4.2: Ion channel genome content of internal nodes on the animal phylogeny.

Ion channel families that underwent large expansions are colored green (GIC), burnt orange (K_v), and black (LIC). Voltage-gated sodium channels, which drive action potentials but did not experience duplication events on the same scale, are colored grey. All other families are left blank but are shown for comparison. Branches with many duplications are colored red and those with net losses are colored blue. Two hypotheses about nervous system origins from the literature are also shown. Open symbols show one hypothesis which posits one origin (open circle) in the common ancestor of animals and two losses (open cross) in placozoans and sponges (Ryan 2014; Ryan et al. 2013). Solid circles show an alternative hypothesis that nervous systems have two origins, one in the common ancestor of cnidarians and bilaterians, and one in the ctenophore lineage (Ryan et al. 2013; Dunn et al. 2008; Moroz 2009; Moroz et al. 2014). Neither hypothesis corresponds with nodes that have large duplication events.

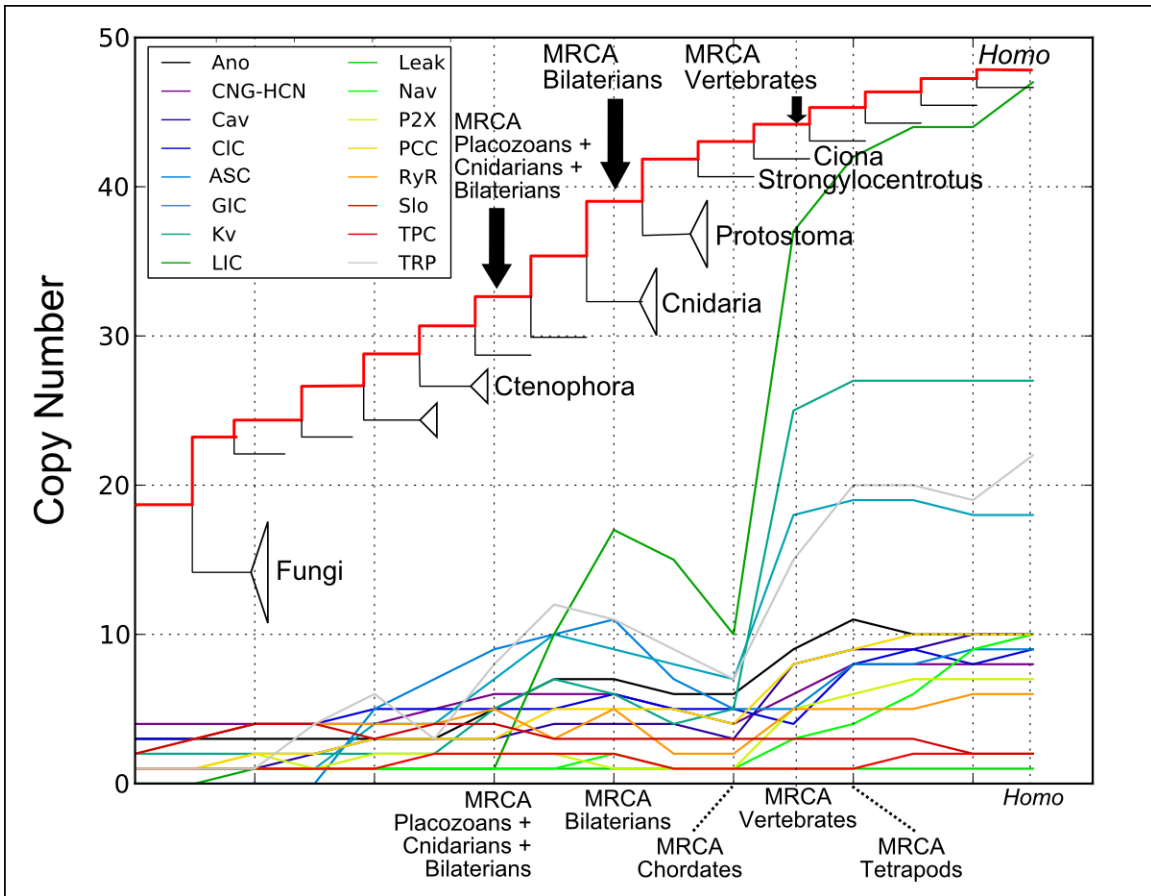

Figure 4.3: Gain and loss of ion channel genes in the lineage leading to humans.

Gene expansion in the MRCA of vertebrates was directly preceded by a large loss event in the MRCA of chordates. The gene families LIC, K_v , GIC, and TRP underwent the largest reductions.

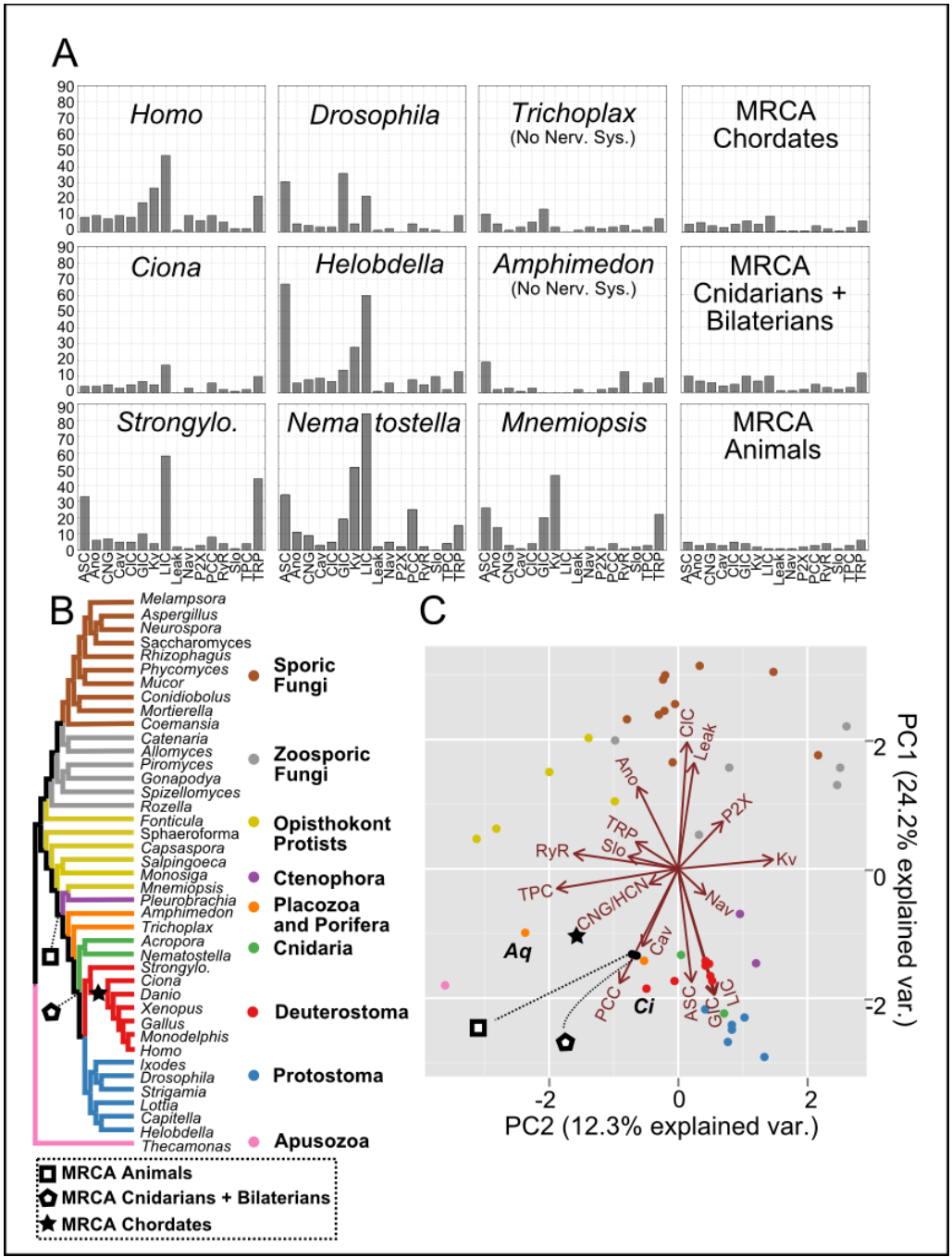

Figure 4.4: Analysis of gene content.

(A) Channel counts of extant species and ancestral species. (B) Species tree showing the relationships of extant taxa and the location of key ancestral nodes. (C) Principal

components analysis of normalized ion channel gene contents for all tips and three ancestral nodes. Proximity in the space of the two principal components indicates similar gene contents. Loadings of the ion channel families are shown as vectors in the two axes. The size and direction of the loading vector indicates its correlation with the two components. Thus families with small vectors do not change greatly among taxa, whereas those with large vectors distinguish different genomes from one another. Loading arrows point to regions where that gene family is in high relative abundance. Labeled species are: *Amphimedon* (*Aq*), *Ciona* (*Ci*).

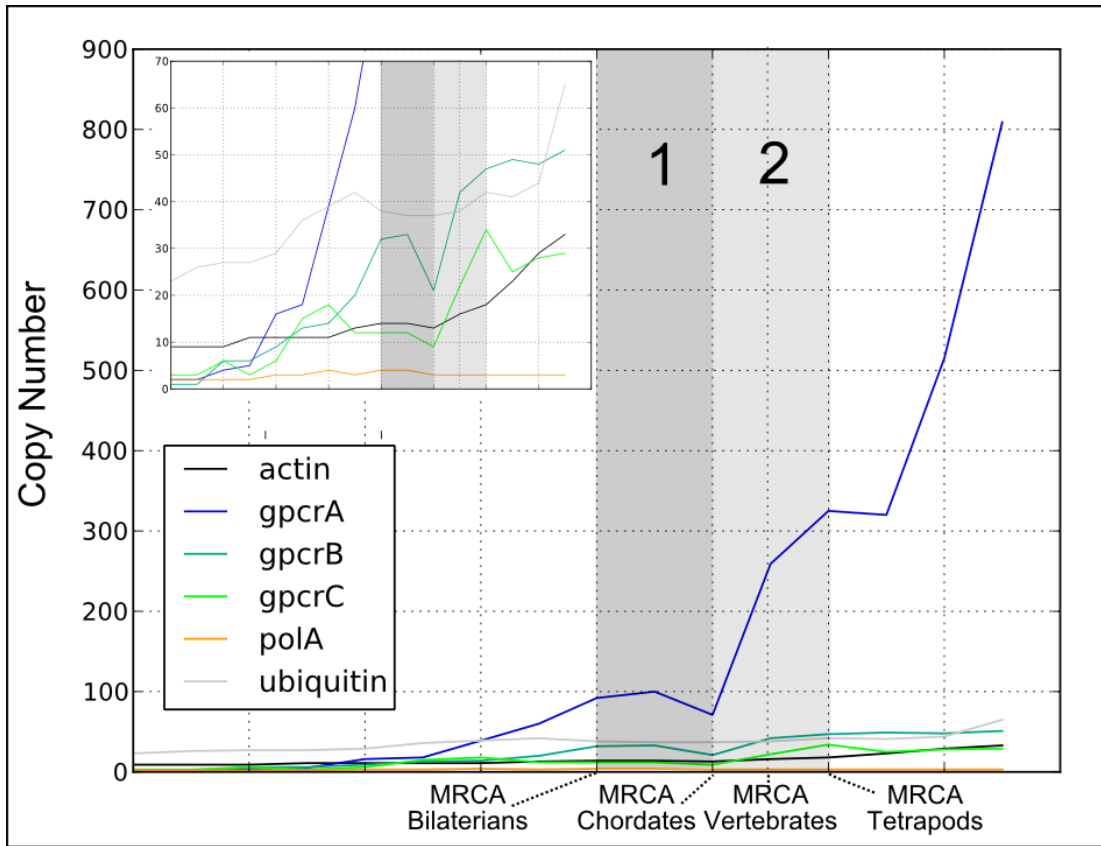

Figure 4.5: Gene gain and loss of GPCRs and three non-nervous system genes in the human lineage.

The inset is shown on a smaller scale so that the pattern of duplication and loss can be seen for genes families other than A-type GPCRs, which are a much larger family. GPCRs resemble ion channels in their pattern of gain and loss whereas the other genes do not. In particular, GPCRs underwent loss events in the common ancestor of chordates followed by a period of gain, primarily in the ancestor of vertebrates. The shaded regions highlight the periods of loss (1) and gain (2).

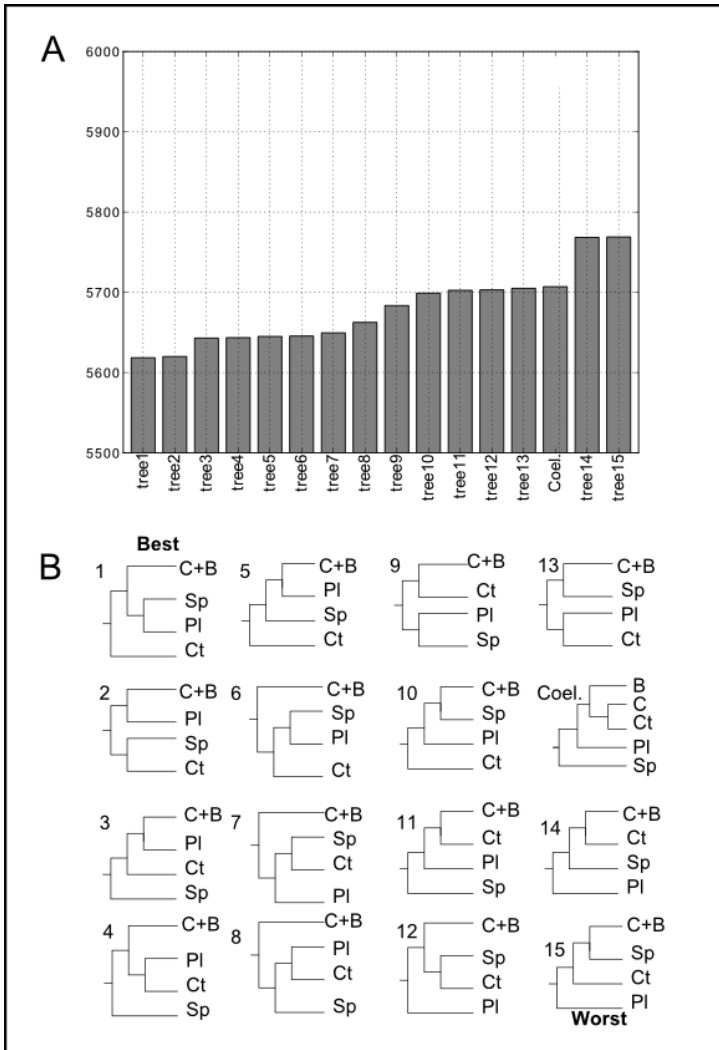

Figure 4.6: Support for different species tree topologies based on parsimony scores of gain and loss events.

Scores were calculated from gene tree/species tree reconciliation in Notung. A.) Scores for different resolutions ordered from best (left) to worst (right). B.) Topologies ordered from best (top left) to worst (bottom right) and numbered as in A.). Taxa are labeled as follows: bilaterians (B), cnidarians (C), ctenophores (Ct), placozoans (Pl), and sponges (Sp). Scores generally support ctenophores as the sister-group of remaining animals, but do not strongly favor this placement over other scenarios with the exception of the Coelenterate hypothesis (“Coel.”, Philippe 2009). The latter tree yields a highly unparsimonious pattern of gain and loss.

Abbreviation	Full Names	Function
Ano	Anoctamin, Ca ²⁺ activated Cl ⁻	Smooth muscle, excitability
ASC	Epithelial (ENaC), acid sensing (ASIC)	Osmoregulation, synaptic transmission
CNG/HCN	Cyclic. nucleotide gated	Sensory transduction, heart
Ca_v	Voltage-gated Ca ⁺ channel	AP, muscle contraction, secretion
ClC	Voltage-gated Cl ⁻ channel	Muscle membrane potential, kidney
GIC	Glutamate receptor, iGluR	Synaptic transmission
LIC	Ligand-gated, Cys-loop receptor	Synaptic transmission
K_v	Voltage-gated K ⁺ channel	AP, membrane potential regulation
Na_v	Voltage-gated Na ⁺ channel	AP propagation
Leak	Sodium leak non-selective (NALCN), Yeast calcium channel (Cch1)	Regulation of excitability (animals), calcium uptake (fungi)
P2X	Purinergic receptor	Vascular tone, swelling
PCC	Polycystine, Mucolipin	Sensory transduction, kidney
RyR	Ryanodine receptor, IP ₃ receptor	Intracellular, muscle contraction
Slo	Voltage and ligand-gated K ⁺	AP, resting potential
TPC	Two-pore channel	Intracellular, NAADP signaling
TRP	Transient receptor potential	Sensory transduction

Table 4.1: Ion channel families used in this study.

The channels play a variety of roles. Some are almost exclusively associated with nervous system function, whereas others have additional roles outside the nervous system.

CONCLUSION

A brief overview of the key findings of this dissertation can be found in Figure C1. Lysine (K) substitutions were found to occur convergently in the pores of cnidarian and bilaterian Na_v channels. Gur-Barzilai *et al.* have recently shown that the lysine substitution in the second domain of cnidarian Na_vs conferred sodium selectivity to these channels (Gur Barzilai et al. 2012). Similar substitutions were found in NALCN channels, and though the precise phylogenetic history is unclear, it appears that these occurred at least three times in animals: once in ecdysozoans, once in lophotrochozoans, and once in deuterostomes (Chapter 2; Senatore et al. 2013). Finally, gene family expansions, primarily in K_v channels and the synaptic channels LIC (Cys-loop receptors), GIC (iGluRs), and ASC (ASIC/ENaC), were found on several peripheral branches, including the common ancestor of vertebrates, the common ancestor of cnidarians, and the common ancestor of ctenophores.

The inadvertent theme of this dissertation has therefore been convergent evolution. Bertil Hille's hypothesis that sodium channels evolved from calcium channels has been shown to not only be correct in the case of voltage-gated channels (Chapter 1), but predictive of other types of sodium channels (Chapters 2 and 3) and in some sense of the whole complement of ion channel proteins (Chapter 4). This suggests that certain principles, in this case the evolution of sodium selectivity from calcium selectivity, can hold across systems and perhaps be a driver of convergence. In this conclusion I will explore some of the ramifications of convergent evolution for the study of the nervous system, focusing first on the use and abuse of comparative studies for the study of ion channel selectivity and then turning to the nervous system as whole. I will finish by discussing some of the challenges that are pointed to by the studies presented here. The theme throughout will be character states and their meaning in evolution.

SODIUM CHANNELS

Evolving a sodium channel appears not to be very difficult. My dissertation documents four independent occurrences, at minimum. Hodgkin and Huxley-type voltage-gated sodium channels (Na_v) evolved twice in animals, once in cnidarians and once in bilaterians. The voltage-insensitive sodium channels (NALCN) evolved at least once, but perhaps three times in animals. Bacterial sodium channels were another independent event. There are at least two other occurrences currently known that I did not cover. A certain splice form of T-type calcium channels in the snail *Lymnaea* can select for sodium over calcium (Senatore et al. 2014). This splice form is present in many other protostomes, and, remarkably, is the only sodium channel expressed in the *Lymnaea* heart. There is also the epithelial sodium channel family (ENaC). These channels have the highest sodium selectivity of all, but are not part of the same family as the others, and select for sodium in a very different fashion (Kellenberger and Schild 2002). There is also some recent evidence the two-pore channel family is actually selective for sodium (Wang et al. 2012) whereas previously they had been described as calcium selective channels (Zhu et al. 2010). This is a relatively new claim from just one group, so further evidence will be necessary.

Sodium channels have therefore evolved at least six times independently, possibly more. This stands in marked contrast to potassium and calcium channels, both of which likely have only one origin, although these origins are so ancient that we can't be entirely sure. Even more remarkable than their multiple origins is that in all cases save the ENaC channels, that is, in all cases involving the voltage-gated family, sodium channels most likely evolved from calcium channels. I have detailed the evidence for this in the previous chapters for the first four sodium channel types. It is obviously the case in the protostome T-type Ca_v channel splice forms as well, and may also be true of the TPCs. Why do sodium channel so reliably evolve from calcium channels, and what does this mean about sodium channel function?

One answer immediately suggests itself: sodium channels are just degenerate, or collapsed, calcium channels. There is much to recommend this hypothesis. First, sodium is one of the smallest physiological cations and the most abundant in sea water and the extracellular fluid. Sodium channels could therefore arise by the formation of simple pores that are small enough to exclude larger cations like potassium. Calcium is in low abundance relative to sodium, so a sodium channel could arise when a calcium channel simply loses the ability to select calcium over sodium. This is likely the case in NALCN channels, which are only weakly selective for sodium (Lu et al. 2007). There is also good evidence that size selection (molecular sieving) plays a large role in sodium channel selectivity (Hille 1975; Hille 2001). But Na_v channels are more selective for sodium than NALCN, and the complete story is more complicated.

Exactly how sodium channel selectivity works is still under debate. Much of the current research on sodium channel selectivity has shifted to the bacterial sodium channels, the only sodium channels that have been crystallized with enough resolution to see the pore. But it is often difficult to interpret how much this work tells us about human Na_v s because it is rarely placed in a rigorous comparative framework. A full description of ion channel selectivity is far beyond my scope, but a few remarks about the molecular basis of selectivity are necessary to appreciate the comparative data and to make a case for how it should be used. Selectivity in potassium channels is by far the best described but is not relevant here, so I will omit discussion of it. I will, however, describe a few aspects of what is known about calcium and sodium channel selectivity in order to show the complexity of comparative molecular studies in the face of convergent evolution.

On the face of it, calcium channels are the real magicians. Sodium ions are about 100 times as abundant as calcium in the extracellular fluid and roughly equal in radius, yet calcium channels effectively exclude them while maintaining a high throughput of calcium ions. Selectivity for calcium over sodium is roughly 1000-fold in L-type calcium channels (Sather and McCleskey 2003; Bertil Hille 2001). Because the ions are similar in size, the selectivity for calcium is thought to rely on the difference in charge between

divalent calcium and monovalent sodium (reviewed in Sather and McCleskey 2003). The data suggests a binding site in the pore that binds calcium more strongly than sodium and prevents sodium from entering. Such a site accounts for the calcium block observed in bi-ionic solutions (Hagiwara 1983), but a simple “sticky pore” with one site would also prevent high throughput of calcium because the ability of calcium to block sodium by binding in the pore would be negatively proportional to the speed with which it could release from the binding site; it is in fact much larger, i.e. calcium is highly effective at blocking sodium but the two ions have a comparable conductance (Hess and Tsien 1984; Bertil Hille 2001). This results in the “anomalous mole fraction effect,” which is when solutions with calcium and sodium together result in channel block, while calcium or sodium alone in the solution leads to large currents. Thus one must posit multiple sites; either two high-affinity sites, or one high-affinity in conjunction with multiple low-affinity sites (Hess and Tsien 1984; Sather and McCleskey 2003).

Two high-affinity sites can account for high-throughput because the electrostatic interaction between two bound calcium ions effectively increases the off-rate while still excluding sodium. Several lines of evidence suggest that there is only one high-affinity site however: the E/E/E/E locus or selectivity filter ring (Sather and McCleskey 2003; Heinemann et al. 1992; Schlieff et al. 1996; J. Yang et al. 1993). These four glutamates project their carboxylate side chains into the pore at the narrowest point, whose negative charge is then thought to coordinate the permeating ions. If, however, there are low-affinity sites on either side (intra- and extra-cellular) of the E/E/E/E locus, calcium ions may “step through” the channel because the energy barriers between the binding sites are sufficiently low (Sather and McCleskey 2003).

This latter scenario seems the most likely, but there is no clarity as to the molecular locus of these low-affinity sites. Several studies favor the idea that the E/E/E/E locus is flexible, and may therefore play the role of both high- and low-affinity site, depending on how many calcium ions are present (Lipkind and Fozzard 2001). Experimental evidence suggests that the four sites do not contribute equally to ion

selectivity. Site E₃ has the greatest effect, followed by E₂ (J. Yang et al. 1993). This suggests an asymmetry among the four sites in the selectivity filter. Perhaps the two central sites, E₂ and E₃, are the high-affinity site with the other two forming a second, low-affinity coordinating site (Sather and McCleskey 2003).

These data are all from Ca_v channels, primarily L-type. Very little work has been done on fungal calcium channels (Cch1), and none has been done on ancestral reconstructions of the calcium channels from which the various sodium channel lineages are thought to have arisen. Nevertheless there is some evidence that these may function in a similar manner to L-type Ca_v channels. For instance, the pore sequence of fungal calcium channels is Q/E/E/E or N/E/E/E. The presence of a glutamine in the first position is known not to strongly affect L-type Ca_v function (Ellinor et al. 1995), suggesting that the filter is functioning in a similar way in both channel types.

The data from Na_v channels suggests that they are indeed only slight modifications of Ca_v channel pores. For instance, Na_v channels can still be blocked by calcium, just like Ca_v channels, but only at much higher, non-physiological concentrations (Armstrong and Cota 1999). Na_v channels probably also have a flexible pore (Lipkind and Fozzard 2008). On the other hand, Na_v channels likely do not hold multiple sodium ions at physiological concentrations (Hille 1975; Hille 2001), unlike Ca_v and K_v channels for their respective ions.

In both Ca_v channels and Na_v, there is now evidence that discrimination between these two ions depends at least in part on residues outside of the main selectivity filter. Gur-Barzilai *et al.* recently showed that the D/K/E/A selectivity filter of cnidarian sodium channels, which developed this lysine (K) in the pore and sodium selectivity convergently with animals (Chapter 1), is not sufficient to induce sodium selectivity in the paralogs with D/E/E/A. Rather, all four pore loops must be replaced in their entirety (Gur Barzilai et al. 2012). Senatore *et al.* found that a splice variant of T-type Ca_v channels in *Lymnaea* is sodium selective, but the variable region is on the pore turret, not the selectivity filter itself (Senatore et al. 2014). Both lines of evidence suggest that,

while the selectivity filter is still the main locus of ion selection in most channels, other regions contribute as well in ways that have not yet been fully fleshed out.

In vertebrate Na_v channels, however, the K_3 residue is known to be necessary, and *almost* sufficient for sodium selectivity (Schlief et al. 1996; Heinemann et al. 1992), and there are several models that try to account for its importance. Charge conserving replacement with arginine (R) is known not to confer sodium selectivity, suggesting the precise side-chain orientation of K is necessary (Lipkind and Fozzard 2008). One model proposes that interactions between the positively charged K_3 and the negatively charged E_2 normally block cations, and only small cations such as lithium and sodium can compete with K_3 for the negative carboxylates on D_1 and E_2 (Lipkind and Fozzard 2008). Note that sites E_2 and K_3 are homologs of E_2 and E_3 in Ca_v channels, the most important sites for calcium selectivity (J. Yang et al. 1993; Sather and McCleskey 2003), and that all the important substitutions in Chapters 1 and 2 above concern charge reversing changes (from E --> K) at one of these two sites, putatively conferring sodium selectivity. Asymmetry is therefore a crucial part of Na_v selectivity, and the main locus, the sites in domains 2 and 3, are the same in sodium and calcium channels. It is suggestive that the charge reversing mutation to a positive lysine leads to selectivity for the monovalent sodium over divalent calcium, as if the lysine were simply supplying the extra charge. If this is, Na_v filters would truly be collapsed Ca_v filters, with the interaction between K_3 and E_2 providing just the right steric environment for sodium to slip through.

Several researchers are investigating how bacterial sodium channels (BacNa_v), which unlike Na_v s are homotetramers and therefore have quasi-symmetric pores with E/E/E/E at the narrowest point (Yue et al. 2002; Ren et al. 2001; Payandeh et al. 2011; Shaya et al. 2011), can be selective for sodium. A crucial difference from Na_v channels is that BacNa_v channels hold multiple ions in the pore at once and single ions are bound much too tightly to account for observed conductances (Furini and Domene 2012; Corry 2013; Finol-Urdaneta et al. 2014). This makes them more like Ca_v and K_v channels and less like Na_v channels. BacNa_v channels also have an anomalous mole fraction

dependence in sodium/potassium solutions. Remarkably, the current is at a *maximum* when both ions are present (~ .8 sodium/potassium with high internal potassium) (Finol-Urdaneta et al. 2014). This is the precise opposite of Ca_v and K_v channels which are blocked in bi-ionic conditions and at a maximum in single-ion solutions. Selectivity may therefore rely on the presence of other ionic species, with sodium skirting around a bound potassium or calcium (Corry 2013; Finol-Urdaneta et al. 2014).

Thus there are several overlapping features of sodium selectivity in eukaryotic Na_v channels and prokaryotic BacNa_v channels. Both have a roughly similar selectivity series (the basic Eisenman series: $\text{Li}^+ > \text{Na}^+ > \text{K}^+ > \text{Rb}^+ > \text{Cs}^+$ (Eisenman and Horn 1983)). In both cases, selectivity relies on the energetics of dehydrating the permeating ion as it binds *and* on steric features. In both cases, some other charged particle interacts with negatively charged binding sites to provide sodium with a better chance of permeating. But the molecular bases for these features are different in BacNa_v and Na_v channels, despite the fact that the pores can be homologized. In Na_v s, the positively charged side chain of K_3 probably competes for the carboxylates in the pore, and can best be competed away by a permeating sodium ion (Lipkind and Fozzard 2008). In BacNa_v channels, another ion species such as potassium helps create the conditions for sodium permeation by binding to a high-affinity site. The ground is therefore ripe for confusion, but also for meaningful comparison if evolutionary analyses are used as a framework for further study.

A key experiment will be the characterization of the channel pores that preceded the extant BacNa_v pores. I have suggested above that these were calcium selective based on their similarity to known calcium selective mutants of BacNa_v and to CatSper . A recent crystal structure has been made of a calcium selective BacNa_v mutant, but is unfortunately without evolutionary guidance or interpretation (Tang et al. 2014). The central question to be answered is whether there are conserved principles of calcium and sodium selective pores over and above their molecular basis. We have seen one candidate already: the presence of another positively charged particle in the pore is important for

sodium selectivity in both Na_v and BaCaNa_v channels, but the nature of the charged particle is different. If similar principles could be found of the calcium selective ancestors of BaCaNa_v channels, we would be well on our way to understanding the evolution of sodium selectivity *as such*, but the ongoing confusion as to the homology between BaCaNa_v channels and eukaryotic channels will preclude such studies as long as the dislocation between the homologous characters and the functionally similar characters is ignored.

ON THE MULTIPLE ORIGINS OF THE NERVOUS SYSTEM

The question of the origin of nervous systems always suffers from a lack of clarity on the defining characteristics of a nervous system. As mentioned in the introduction, the sophistication of electrical excitability within cells appears to be a continuum (Bishop 1956), ruling out its use as a criterion for defining a nervous system. The complexity of inter-cell connections may also be a continuum, or at least admit of several states that fulfill largely similar purposes and cannot be easily ranked in their complexity. Such states include: 1.) An electrically coupled sheet, like that in cnidarians and tunicates; 2.) Non-polar and diffuse neuronal connections, as in cnidarians and ctenophores; 3.) Non-polar and heavily branched neurons like those in invertebrate bilaterians; 4.) Vertebrate-like polar neurons (Mackie 1990; Bullock and Horridge 1965). Another possibility is an excitable syncytium. *Trichoplax* has a contractile and presumably excitable syncytium between its dorsal and ventral layers that appears to serve as both muscle and nervous system. I have observed that *Trichoplax* can reorient itself when it lands on its dorsal side after being picked up in a transfer pipette.

Asking whether nervous systems have one origin or several may therefore be an ill-posed question. Nevertheless, I would like to suggest one way in which these continua of complex signaling systems might be more profitably understood, and add one more theory to the morass of others. As mentioned in the introduction, many of the existing theories seek to explain, in Bullock and Horridge's words, the "combination of connectedness and specialization for propagating an excited state" that defines a nervous

system. This definition is acknowledged to be loose. Is there a qualitative break between this “specialization” of nervous systems and the electrical activity of non-nervous tissue? I think there is.

We saw several cases of action potentials outside the animal kingdom in the introduction. One of the best studied is the calcium-based action potential of *Paramecium*. This action potential serves to deliver calcium to the cilia which then causes them to reverse the direction of their beat. The length of the action potential therefore sets the time scale over which the change in behavior happens, and the calcium drives both the regeneration of the action potential (*via* voltage-gated channels) and the cellular signal. A direct link between the ion involved in the action potential and the behavioral effector is not unique to calcium-based action potentials. In the Venus fly trap, the action potential is thought to effect closure by affecting the osmotic pressure or pH in the cells of the trap wall (Simons 1981), causing them to slacken. Again, the action potential is the direct effector of the behavior.

This differs qualitatively from the way that action potentials are most often employed in animal nervous systems. Action potentials in nerves form a code in which the spikes and spike trains are just the symbols, and not direct effectors of the behavior. I have shown in the introduction that this understanding dates back to the 17th century. Hille, Bishop and Hagiwara all make reference to the qualitative difference between calcium-based action potentials and symbolic ones based on sodium (Bertil Hille 2001; Bishop 1956; Hagiwara 1983). Hille hypothesized that the duplication that resulted in the Na_v and the animal Ca_v lineages allowed the ancestral calcium-based action potential to be partitioned into a calcium delivery system, carried by Ca_v channels, and a neural code of action potentials, carried by Na_v channels. This corresponds to an “escape from adaptive conflict” model of gene duplication (Hughes 1994), where two functions cannot both be optimized in one gene and this conflict is then relieved by the duplication event. Thus Hille’s hypothesis is based on adaptation. But the fact that animal gene compliments seem to have undergone several reversals back towards calcium-based

signaling suggests instead that calcium-based signaling and sodium-based signaling are two alternate stable states in which animals can specialize (Chapter 4). Furthermore, the fact that the large gene duplication events described in Chapter 4 happened later than any currently contemplated starting point for nervous systems suggests that nervous systems did not take off in complexity for a very long period. I would therefore like to suggest a hypothesis of the evolution of neural codes that is based on neutral evolution.

It seems possible that action potentials that directly trigger behaviors can evolve into symbols or codes via a process resembling that of behavioral ritualization. Ritualization describes how behaviors that initially exist for one purpose (e.g. foraging), begin to be used as a cue for conspecifics and then steadily evolve into signals as they come under a new form of selection, such as sexual selection. It is then possible for them to lose their original purpose and become, for instance, exaggerated or “supernormal.” Action potentials may similarly come to trigger other processes in the behavioral pathway, becoming both indirect mediators of behavior and the direct mechanistic cause. The action potentials would then steadily be subducted deeper into the system, becoming “symbols of the motion to be performed,” as the intermediate processes take over the task of triggering the behavior. Such a build-up of intermediate pathways constitutes constructive neutral evolution (Stoltzfus 1999), and these intermediates could come to play any number of modulatory roles, such as amplification (Jekely 2011). One such process is schematized in Figure C2. It differs from other views of nervous system evolution in that the buildup of complexity is at first a neutral process, and only later, after divergence, do the new components become a substrate for lineage-specific adaptations.

There is an important quality that differentiates the symbolic system (after subduction) from the direct system. In the symbolic system, the precise makeup of the parts, their types and organization, may easily be one of several states and still give rise to the exact same output. The greater the complexity, the more likely it is that other organizational schema may perform the same role by simply reorganizing the sign and

strength of different internal symbols. Thus the particular elements of the system, say the action potentials themselves, are “screened off” from selection (to borrow a term from (Roth 1991)) by the organization of the whole system. They are free to drift to different states while maintaining the same output as long as such states are available via neutral one-step changes. This is called “systems drift” (True and Haag 2001). We are therefore permitted a fairly simple definition of the nervous system: it is any cellular system which includes interconnected excitable cells with a purely *symbolic* electrical code that is not directly exposed to a selective regime, i.e. where systems drift is possible.

The process I have described imagines a large role for creative neutral evolution (Stoltzfus 1999). I think this helps explain the patterns we see along the animal tree. *Trichoplax*, for instance, has no nervous system under my definition but seems to get around just fine. More than fine, it can roll over to right itself, find food, move with two different modes (gliding and amoeboid), and divide by fission. Nematodes are about the same size as *Trichoplax* but have nervous systems and perhaps a more complicated behavioral repertoire. On the other hand they have lost their sodium channels and do not have all-or-none action potentials (Lockery and Goodman 2009). Echinoderms have a very similar lifestyle to *Trichoplax* and are probably not much more complex behaviorally. They are much larger and have a nervous system, but only possess Na_v channels with D/E/E/A in the pore and probably don't have sodium-based action potentials (J. L. Cobb 1989; Chapter 1). If the early evolution of the nervous system involved a largely neutral accumulation of complexity, as I have imagined it, and did not coincide with a large fitness advantage, as many authors assume (Hille 2001; Jekely 2011; Passano 1963), then there is no reason to imagine that nervous systems have not evolved and been lost many times throughout animal evolution. This is especially true if some sort of excitable but non-nervous cell type like that of *Trichoplax* was present in the ancestor, which seems likely given the full complement of ion channels present then (Chapter 4). It will be particularly interesting to see whether this scenario can be used to

understand the evolution of the genomic and neuroendocrine action potential (Hofmann 2010) and therefore whether it can be understood to be a more general process.

HOMOLOGY

We have seen two cases of convergent evolution on two vastly different scales of complexity. The states “sodium selective” and “nervous system” are not monophyletic, and this can lead to problems in interpretation. When one says “Na_v” does one mean any voltage-gated channel selective for sodium, or does one mean the monophyletic group in which animal Na_vs fall? As data acquisition becomes easier for more and more levels of biological organization, mismatches in the phylogenetic pattern of phenotypes, mechanisms, and genotypes are likely to be found more and more often. The continuity of character states over evolutionary time, the most common criterion of homology, may therefore be a problematic touchstone in the era of high-throughput data acquisition.

Some researchers have already begun to extend the concept of homology to meet the new challenges. The three best known extensions are “deep homology” (Shubin, Tabin, and Carroll 2009), “phenology” (McGary et al. 2010) and “systems drift” (True and Haag 2001), which has already been mentioned above. These describe cases where, respectively, convergent phenotypes rely on the same genes, divergent phenotypes rely on the same genes, and where conserved phenotypes rely on different genes (Fig. C3). All three definitions address cases where phylogenetic continuity does not correspond across different levels of organization, with either the phenotype or the genotype being discontinuous while the other is continuous. The new definitions are helpful, but there are key differences between the cases they describe. For instance, deep homology and phenology identify mechanistic similarities between seemingly distant phenotypes. These shared mechanisms can be used as the basis of a powerful model systems approach (McGary et al. 2010). But in systems drift, the mechanisms are more incidental to the phenotype and the species involved are therefore not expected to be good mechanistic models of one another.

Systems drift seems to be ubiquitous in complex systems (True and Haag 2001), and in many cases may be indistinguishable from convergence if adequate comparative data is not available. As more details of complex systems are uncovered, I suspect that non-trivial cases of systems drift and convergence will be uncovered with them. In fact, most complex phenotypic characters are likely to be a mixture of components, some of which were co-inherited and thus also homologous, some of which are lineage-specific and non-homologous, and some which are structural necessities that have remained constant in terms of *function*, but which may be performed by different non-homologous mechanisms in different organisms either because of convergence or systems drift. It may therefore become inappropriate to use homology-as-monophyly as a blanket justification for the phenotypic comparisons employed in a model systems approach.

In my opinion, too much effort is exerted in pursuit of solid criteria for assigning homology, and not enough in the explaining what we hope to learn from such assignment in the first place. Homology has been called the basis of comparative biology (Hall 1994). Why do we want to identify homologous characters in comparative studies? I think Owen's original definition is useful here: A homolog is "the same organ in different animals under every variety of form and function," whereas an analog is "a part or organ in one animal which has the same function as another part or organ in a different animal" (Owen 1843, quoted from Hall 1993). Homology therefore has two main aspects: it assigns "sameness," and it provides a contrast to analogy, where similarity is due to function. Homology and analogy are two ways of answering the question "why are these characters similar?" And, ever since homology came to be interpreted in an evolutionary framework, they have corresponded to the two forms of ultimate causation that Tinbergen adapted from Aristotle: homology identifies similarity due to phylogenetic history, and analogy identifies similarity due to function, or survival value (Tinbergen 1963).

In practice, homology is mostly used to highlight phylogenetic continuity of a character state in contrast to convergence so that the characters can be used for some other end; phylogenetic estimation, perhaps, or as a model system for studying

mechanisms. The problem, as we have seen above, is that the phylogenetic continuity of a character at one level of organization does not guarantee the continuity of characters at different levels of the same phenotype. It is therefore incorrect to assume that homologous characters rely on similar mechanisms, and are therefore directly comparable, but convergent characters do not and are not. The problem is likely to be general because the common descent of all life-forms means that all or most characters are homologous when viewed at a sufficiently large time scale. It is therefore not very useful to search for a single, unified definition of sameness when multiple levels of organization are considered.

On the other hand, the second aspect of homology, its use as a contrast to functional similarity, seems especially useful and pertinent in the modern era of complex systems. All character states will have aspects that are due to historical contingency (Gould and Lewontin 1979) and aspects that are due to functional constraint. These tightly constrained aspects can be phylogenetically continuous, but they can just as easily have come about by convergence or have experienced systems drift at lower levels of organization. Homology assignment can still be profitable if we use it to separate aspects of complex systems that are caused by historical contingency from those caused by functional constraint. Such aspects may exist at any level and, crucially, any given character state is likely to have aspects that are due to history and aspects that are due to function. These aspects may be genes, mechanistic principles, developmental systems, or selective regimes, and it is the work of comparative analysis to discern the relative importance of phylogenetic versus functional causation for each. Which components are used for downstream studies depends on the nature of those studies. If one wishes to find phylogenetically informative characters, characters that are chiefly defined by their history must be used, but if design principles are being sought, an analog may be more powerful. However, the comparative method must always be used to identify which characters are necessary and which are historically contingent.

It is a routine part of comparative biology to discern which components of a system are homologous. But what would it mean to study the survival value or function of non-homologous traits in a comparative framework? Can mechanisms be comparable if they are not homologous? Can common principles be found among phenotypes which have evolved convergently or whose mechanisms have drifted apart? The way in which an ion channel selects for a certain ion is an ideal test case for such a comparison. It seems appropriate to study sodium selectivity *as such* because common principles are likely to play in the different independently evolved lineages. The presence of a non-sodium charge in the pore of sodium channels, whether the lysine side-chain in eukaryotic Na_vs or a potassium ion in BacNa_vs, is one such principle.

The nervous system is a more complicated case. I showed in Chapter 4 that the same ion channel types radiated several times on branches where nervous systems may have evolved independently. This suggests some commonality in the way that these ion channels are employed, even though the families radiated independently. Such a pattern hints at some broad design principle that makes, for instance, a gene duplication of a K_v channel more likely to fix than a duplicate Na_v. Cases of convergent evolution are eminently suited for the study of such design principles. In Ctenophores, however, the LICs, which are the largest ion channel family in vertebrates and cnidarians, are absent. Moroz (2014) suggested that ASCs may be playing a major role as synaptic ion channels in ctenophores. If ASCs are taking the place of LICs, then perhaps they can be used as models in some sense, but it is also possible that the nervous systems of ctenophores have fundamental differences that preclude such a comparison. For complex tissue types like nervous systems, such situations are likely to be ubiquitous and finding general mechanistic principles may therefore be more difficult.

In my definition of nervous systems, it is difficult to compare mechanisms across taxa *in principle*. This is because, in my definition, nervous systems must have a code, and codes can always be different than they are; that is, they can experience systems drift at almost every level. Developmental systems, for which the term systems drift was

coined (True and Haag 2001), are also codes and systems drift is therefore also a part of them in principle. Another classic case is sex determination: many types of sex determination exist in vertebrates, but a differentiation of the sexes is thought to be homologous. I think it is useful, therefore, for comparative studies to distinguish between phenotypes that can experience systems drift in principle and those that cannot. All systems can drift somewhat, of course, but there is a difference between mechanisms whose function is tightly constrained by certain physical parameters and those that are only bounded by their signal fidelity and the energy it takes to maintain them. Intriguingly, a recent study showed that genes involved in morphology evolve differently than genes affecting physiological traits; the former being more likely to diverge in expression pattern and the latter evolving by changes to the coding sequence and gain/loss (Liao, Weng, and Zhang 2010). It would be interesting to see whether similar patterns can be seen when genes are categorized by how well they are “screened off” from selection by the system in which they are expressed.

The two types of systems are not equally useful for the model systems approach. In systems with intrinsic physical constraints, for instance the atomic radius of sodium, the comparative method can be used to determine which parts of the system are due to historical contingency, and are therefore incidental, in order to expose which parts are necessary, and therefore predictive. The necessary components of different channels can be true models of each other, even if they are analogs rather than homologs. But in cases where systems drift is ubiquitous, it is less likely that necessary components can be found, and a model systems approach will have to contend with an indeterminately large number of configurations or architectures of the underlying mechanism. It is easy to imagine how such scenarios could confuse the search for models of complex diseases, for instance.

Is it correct to call a phenotype a “character state” if its underlying mechanism can drift indeterminately? Such questions will have to be dealt with if clarity is to be achieved in the era of high-throughput. It is possible that as the level of detail becomes

greater, we will find that even simple systems like ion channel pores can be solved by an indeterminate number of mechanisms. Conversely, it is not unthinkable that broad principles may be found for structures as complex as a nervous system. But I think the dichotomy I've presented here between systems that can drift in principle and those that cannot is a useful one, even if it's a simplification. Comparative studies always depend on simplified version of homology, but a subtle shift in the current paradigm along the lines I've indicated may be useful as the power and precision of systems biology increases.

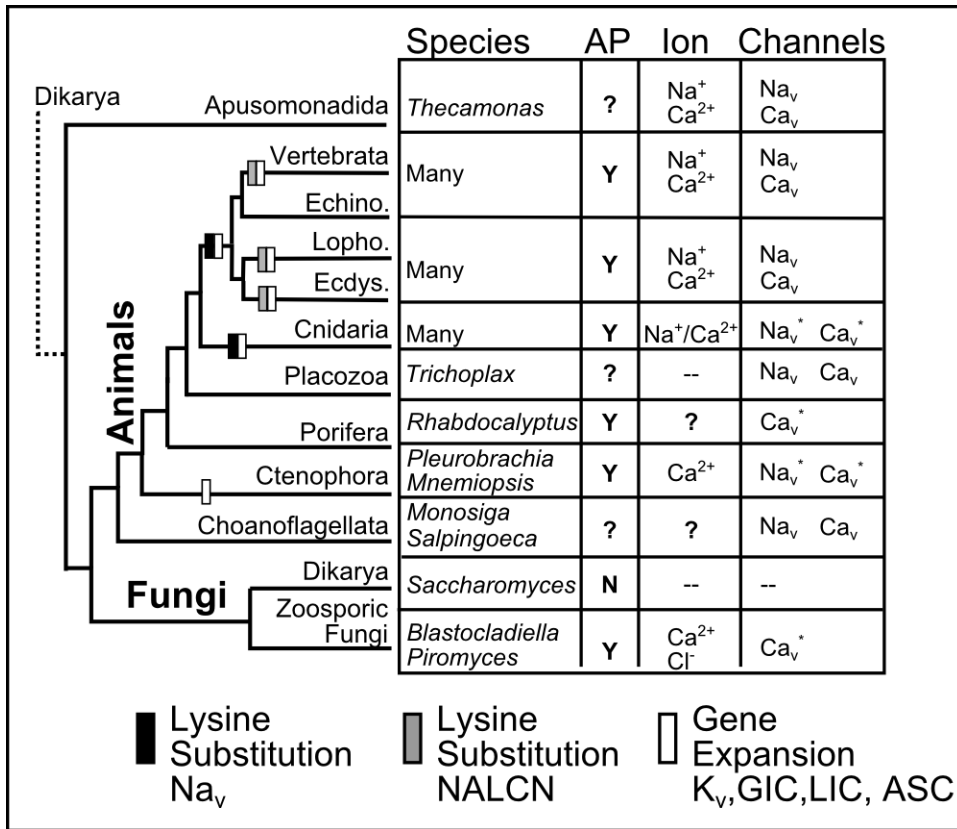

Figure C1: Brief summary of findings.

The tree reflects new information about the branching order of animals discussed in Chapter 4. Key lysine (K) substitutions occurred convergently in Na_v and NALCN channels at several places on the tree (Chapters 1 and 2, respectively). Convergent gene expansions of K_v channels and three synaptic families, ASC, GIC, and LIC, occurred in several lineages. Some taxonomic names have been shortened thus: “Echino”: echinoderms; “Lopho”: lophotrocozoans; “Ecdys”: ecdysozoans.

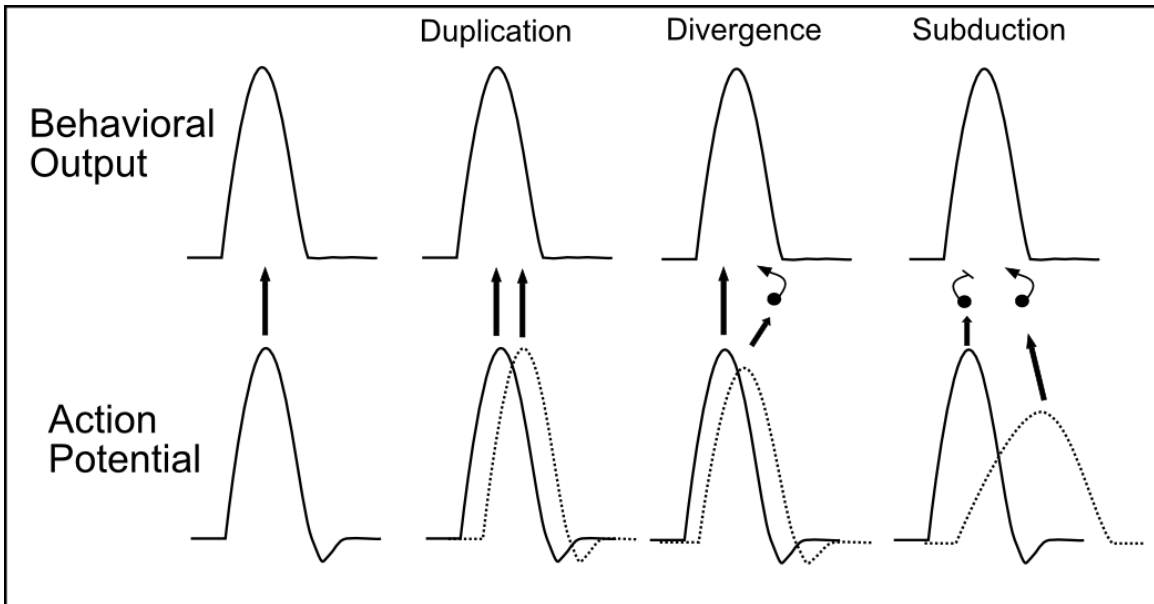

Figure C2: Constructive neutral evolution of a symbolic neural code.

One process is shown by which action potentials may change from the direct agent of behavioral output, like in *Paramecium*, to a neural code via constructive neutral evolution. Other paths could easily be imagined, such as the interposition of elements without duplication, or prior to it.

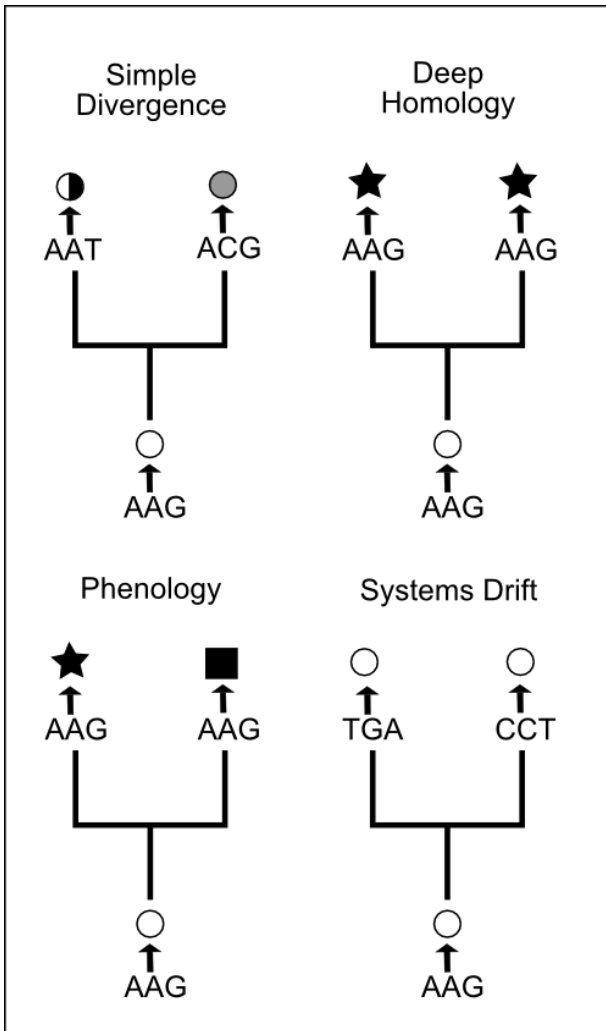

Figure C3: Four kinds of homology.

The simple case is shown at top left. Genotypes encoding phenotypes are depicted as arrows towards symbols. All three extended definitions constitute cases where homology is not constant across levels of organization.

BIBLIOGRAPHY

- Abascal, Federico, Rafael Zardoya, and David Posada. 2010. "ProtTest: Selection of Best-Fit Models of Protein Evolution." *Bioinformatics* 21 (9): 2104–5. Accessed December 5. doi:10.1093/bioinformatics/bti263.
- Adrian, Edgar Douglas. 1914. "The All-or-None Principle in Nerve." *The Journal of Physiology* 47 (6): 460–74.
- Aldrich, Richard W. 2001. "Fifty Years of Inactivation." *Nature* 411 (6838): 643–44.
- Aldrich, R. W., D. P. Corey, and C. F. Stevens. 1983. "A Reinterpretation of Mammalian Sodium Channel Gating Based on Single Channel Recording." *Nature* 306 (5942): 436–41.
- Altschul, Stephen F., Warren Gish, Webb Miller, Eugene W. Myers, and David J. Lipman. 1990. "Basic Local Alignment Search Tool." *Journal of Molecular Biology* 215 (3): 403–10. doi:10.1016/S0022-2836(05)80360-2.
- Altschul, Stephen F., Thomas L Madden, Alejandro A Schäffer, Jinghui Zhang, Zheng Zhang, Webb Miller, and David J Lipman. 1997. "Gapped BLAST and PSI-BLAST: A New Generation of Protein Database Search Programs." *Nucleic Acids Research* 25 (17): 3389–3402. doi:10.1093/nar/25.17.3389.
- Anderson, P. A., and W. E. Schwab. 1983. "Action Potential in Neurons of Motor Nerve Net of *Cyanea* (Coelenterata)." *J Neurophysiol* 50 (3): 671–83.
- Arendt, Detlev, Alexandru S Denes, Gáspár Jékely, and Kristin Tessmar-Raible. 2008. "The Evolution of Nervous System Centralization." *Philosophical Transactions of the Royal Society B: Biological Sciences* 363 (1496): 1523–28. doi:10.1098/rstb.2007.2242.
- Armstrong, C. M., and Gabriel Cota. 1999. "Calcium Block of Na⁺ Channels and Its Effect on Closing Rate." *Proceedings of the National Academy of Sciences of the United States of America* 96 (7): 4154–57.
- Beilby, M. J. 1984. "Calcium and Plant Action Potentials." *Plant, Cell & Environment* 7 (6): 415–21. doi:10.1111/j.1365-3040.1984.tb01431.x.
- Bishop, George H. 1956. "Natural History of the Nerve Impulse." *Physiological Reviews* 36 (3): 376–99.
- Blinks, L. R., E. S. Harris, and W. J. V. Osterhout. 1929. "Studies on Stimulation in *Nitella*." *Proceedings of the Society for Experimental Biology and Medicine. Society for Experimental Biology and Medicine (New York, N.Y.)* 26 (9): 836–38. doi:10.3181/00379727-26-4549.
- Boussau, Bastien, E. Olof Karlberg, A. Carolin Frank, Boris-Antoine Legault, and Siv G. E. Andersson. 2004. "Computational Inference of Scenarios for A-Proteobacterial Genome Evolution." *Proceedings of the National Academy of Sciences of the United States of America* 101 (26): 9722–27. doi:10.1073/pnas.0400975101.
- Bryson, James W., Stephen F. Betz, Helen S. Lu, Daniel J. Suich, Hongxing X. Zhou, Karyn T. O'Neil, and William F. DeGrado. 1995. "Protein Design: A Hierarchic Approach." *Science* 270 (5238): 935–41. doi:10.1126/science.270.5238.935.

- Bullock, Theodore H., and Horridge, Adrian G. 1965. *Structure and Function in the Nervous Systems of Invertebrates*. 1st ed. Vol. 1. 3 vols. W.H. Freeman and Company.
- Burkhardt, Pawel, Christian M. Stegmann, Benjamin Cooper, Tobias H. Kloepper, Cordelia Imig, Frédérique Varoquaux, Markus C. Wahl, and Dirk Fasshauer. 2011. "Primordial Neurosecretory Apparatus Identified in the Choanoflagellate *Monosiga Brevicollis*." *Proceedings of the National Academy of Sciences* 108 (37): 15264–69. doi:10.1073/pnas.1106189108.
- Cai, Xinjiang, and D. E. Clapham. 2011. "Ancestral Ca²⁺ Signaling Machinery in Early Animal and Fungal Evolution." *Molecular Biology and Evolution*, June. doi:10.1093/molbev/msr149.
- Cai, Xinjiang. 2008. "Unicellular Ca²⁺ Signaling 'Toolkit' at the Origin of Metazoa." *Molecular Biology and Evolution* 25 (7): 1357–61. doi:10.1093/molbev/msn077.
- . 2012. "Ancient Origin of Four-Domain Voltage-Gated Na⁺ Channels Predates the Divergence of Animals and Fungi." *Journal of Membrane Biology* 245 (2): 117–23. doi:10.1007/s00232-012-9415-9.
- Cai, Xinjiang, and David E Clapham. 2012. "Ancestral Ca²⁺ Signaling Machinery in Early Animal and Fungal Evolution." *Molecular Biology and Evolution* 29 (1): 91–100. doi:10.1093/molbev/msr149.
- Caldwell, John H., Jennifer Van Brunt, and Franklin M. Harold. 1986. "Calcium-Dependent Anion Channel in the Water mold, *Blastocladiella Emersonii*." *The Journal of Membrane Biology* 89 (1): 85–97. doi:10.1007/BF01870898.
- Capella-Gutiérrez, Salvador, José M. Silla-Martínez, and Toni Gabaldón. 2009. "trimAl: A Tool for Automated Alignment Trimming in Large-Scale Phylogenetic Analyses." *Bioinformatics* 25 (15): 1972–73. doi:10.1093/bioinformatics/btp348.
- Caron, David A., Alexandra Z. Worden, Peter D. Countway, Elif Demir, and Karla B. Heidelberg. 2009. "Protists Are Microbes Too: A Perspective." *ISME Journal: Multidisciplinary Journal of Microbial Ecology* 3 (1): 4–12. doi:10.1038/ismej.2008.101.
- Carr, M., B. S. C. Leadbeater, R. Hassan, M. Nelson, and S. L. Baldauf. 2008. "Molecular Phylogeny of Choanoflagellates, the Sister Group to Metazoa." *Proceedings of the National Academy of Sciences* 105 (43): 16641–46. doi:10.1073/pnas.0801667105.
- Catterall, William A. 2000. "From Ionic Currents to Molecular Mechanisms: The Structure and Function of Voltage-Gated Sodium Channels." *Neuron* 26 (1): 13–25. doi:10.1016/S0896-6273(00)81133-2.
- Cavalier-Smith, Thomas, and Ema E. -Y. Chao. 2003. "Phylogeny of Choanozoa, Apusozoa, and Other Protozoa and Early Eukaryote Megaevolution." *Journal of Molecular Evolution* 56 (5): 540–63. doi:10.1007/s00239-002-2424-z.
- Charalambous, Kalypso, and B A Wallace. 2011. "NaChBac: The Long Lost Sodium Channel Ancestor." *Biochemistry* 50 (32): 6742–52. doi:10.1021/bi200942y.

- Chen, Chuming, Darren A. Natale, Robert D. Finn, Hongzhan Huang, Jian Zhang, Cathy H. Wu, and Raja Mazumder. 2011. "Representative Proteomes: A Stable, Scalable and Unbiased Proteome Set for Sequence Analysis and Functional Annotation." *PLoS ONE* 6 (4): e18910. doi:10.1371/journal.pone.0018910.
- Chen, Kevin, Dannie Durand, and Martin Farach-Colton. 2000. "NOTUNG: A Program for Dating Gene Duplications and Optimizing Gene Family Trees." *Journal of Computational Biology* 7 (3-4): 429–47. doi:10.1089/106652700750050871.
- Chiu, J., R. DeSalle, H. M. Lam, L. Meisel, and G. Coruzzi. 1999. "Molecular Evolution of Glutamate Receptors: A Primitive Signaling Mechanism That Existed before Plants and Animals Diverged." *Molecular Biology and Evolution* 16 (6): 826–38.
- Cobb, James LS. 1989. "Enigmas of Echinoderm Nervous Systems." In *Evolution of the First Nervous Systems*, 329–37. Springer.
- Cobb, Matthew. 2002. "Exorcizing the Animal Spirits: Jan Swammerdam on Nerve Function." *Nature Reviews Neuroscience* 3 (5): 395–400. doi:10.1038/nrn806.
- Cock, Peter J. A, Tiago Antao, Jeffrey T Chang, Brad A Chapman, Cymon J Cox, Andrew Dalke, Iddo Friedberg, et al. 2009. "Biopython: Freely Available Python Tools for Computational Molecular Biology and Bioinformatics." *Bioinformatics* 25 (11): 1422–23. doi:10.1093/bioinformatics/btp163.
- Cole, Kenneth Stewart. 1968. *Membranes, Ions, and Impulses: A Chapter of Classical Biophysics*. Vol. 5. Univ of California Press.
- Corry, Ben. 2013. "Na⁺/Ca²⁺ Selectivity in the Bacterial Voltage-Gated Sodium Channel NavAb." Edited by Frances Separovic. *PeerJ* 1 (February): e16. doi:10.7717/peerj.16.
- Davies, Sarah W., Eli Meyer, Sarah M. Guermond, and Mikhail V. Matz. 2014. "A Cross-Ocean Comparison of Responses to Settlement Cues in Reef-Building Corals." *PeerJ* 2: e333.
- Doyle, Declan A., João Morais Cabral, Richard A. Pfuetzner, Anling Kuo, Jacqueline M. Gulbis, Steven L. Cohen, Brian T. Chait, and Roderick MacKinnon. 1998. "The Structure of the Potassium Channel: Molecular Basis of K⁺ Conduction and Selectivity." *Science* 280 (5360): 69–77. doi:10.1126/science.280.5360.69.
- Dunn, Casey W., Andreas Hejnol, David Q. Matus, Kevin Pang, William E. Browne, Stephen A. Smith, Elaine Seaver, et al. 2008. "Broad Phylogenomic Sampling Improves Resolution of the Animal Tree of Life." *Nature* 452 (7188): 745–49. doi:10.1038/nature06614.
- Eckert, R, and P Brehm. 1979. "Ionic Mechanisms of Excitation in Paramecium." *Annual Review of Biophysics and Bioengineering* 8 (1): 353–83. doi:10.1146/annurev.bb.08.060179.002033.
- Eddy, Sean R. 1998. "Profile Hidden Markov Models." *Bioinformatics (Oxford, England)* 14 (9): 755–63.
- Eisenman, George, and Richard Horn. 1983. "Ionic Selectivity Revisited: The Role of Kinetic and Equilibrium Processes in Ion Permeation through Channels." *The Journal of Membrane Biology* 76 (3): 197–225. doi:10.1007/BF01870364.

- Ellinor, Patrick T., Jian Yang, William A. Sather, Ji-Fang Zhang, and Richard W. Tsien. 1995. "Ca²⁺ Channel Selectivity at a Single Locus for High-Affinity Ca²⁺ Interactions." *Neuron* 15 (5): 1121–32. doi:10.1016/0896-6273(95)90100-0.
- Emes, Richard David, and Seth G. N. Grant. 2011. "The Human Postsynaptic Density Shares Conserved Elements with Proteomes of Unicellular Eukaryotes and Prokaryotes." *Frontiers in Neuroscience* 5 (March). doi:10.3389/fnins.2011.00044.
- Fatt, Po, and B. Katz. 1953. "The Electrical Properties of Crustacean Muscle Fibres." *The Journal of Physiology* 120 (1-2): 171–204.
- Febvre-chevalier, Colette, Andre Bilbaut, Quentin Bone, and Jean Febvre. 1986. "Sodium-Calcium Action Potential Associated with Contraction in the Heliozoan *Actinocoryne Contractilis*." *Journal of Experimental Biology* 122 (1): 177–92.
- Finn, R. D., J. Clements, and S. R. Eddy. 2011. "HMMER Web Server: Interactive Sequence Similarity Searching." *Nucleic Acids Research* 39 (Web Server): W29–37. doi:10.1093/nar/gkr367.
- Finol-Urdaneta, Rocío K., Yibo Wang, Ahmed Al-Sabi, Chunfeng Zhao, Sergei Y. Noskov, and Robert J. French. 2014. "Sodium Channel Selectivity and Conduction: Prokaryotes Have Devised Their Own Molecular Strategy." *The Journal of General Physiology* 143 (2): 157–71. doi:10.1085/jgp.201311037.
- Fischer, Marc, Norbert Schnell, Jayne Chattaway, Paul Davies, Graham Dixon, and Dale Sanders. 1997. "The *Saccharomyces Cerevisiae* CCH1 Gene Is Involved in Calcium Influx and Mating." *FEBS Letters* 419 (2–3): 259–62. doi:10.1016/S0014-5793(97)01466-X.
- Fukuoka, Hajime, Tomoyuki Wada, Seiji Kojima, Akihiko Ishijima, and Michio Homma. 2009. "Sodium-Dependent Dynamic Assembly of Membrane Complexes in Sodium-Driven Flagellar Motors." *Molecular Microbiology* 71 (4): 825–35. doi:10.1111/j.1365-2958.2008.06569.x.
- Furini, Simone, and Carmen Domene. 2012. "On Conduction in a Bacterial Sodium Channel." *PLoS Comput Biol* 8 (4): e1002476. doi:10.1371/journal.pcbi.1002476.
- Garm, A., P. Ekström, M. Boudes, and D.-E. Nilsson. 2006. "Rhopalia Are Integrated Parts of the Central Nervous System in Box Jellyfish." *Cell and Tissue Research* 325 (2): 333–43. doi:10.1007/s00441-005-0134-8.
- Gazzarrini, Sabrina, Ming Kang, Svetlana Epimashko, James L. Van Etten, Jack Dainty, Gerhard Thiel, and Anna Moroni. 2006. "Chlorella Virus MT325 Encodes Water and Potassium Channels That Interact Synergistically." *Proceedings of the National Academy of Sciences* 103 (14): 5355–60. doi:10.1073/pnas.0600848103.
- Gehring, W. J. 2005. "New Perspectives on Eye Development and the Evolution of Eyes and Photoreceptors." *Journal of Heredity* 96 (3): 171–84. doi:10.1093/jhered/esi027.
- Goldin, Alan L. 2003. "Mechanisms of Sodium Channel Inactivation." *Current Opinion in Neurobiology* 13 (3): 284–90. doi:10.1016/S0959-4388(03)00065-5.

- Gould, Stephen Jay, and Richard C. Lewontin. 1979. "The Spandrels of San Marco and the Panglossian Paradigm: A Critique of the Adaptationist Programme." *Proceedings of the Royal Society of London. Series B. Biological Sciences* 205 (1161): 581–98.
- Gur Barzilai, Maya, Adam M. Reitzel, Johanna E.M. Kraus, Dalia Gordon, Ulrich Technau, Michael Gurevitz, and Yehu Moran. 2012a. "Convergent Evolution of Sodium Ion Selectivity in Metazoan Neuronal Signaling." *Cell Reports* 2 (2): 242–48. doi:10.1016/j.celrep.2012.06.016.
- Hagiwara, S. 1983. *Membrane Potential-Dependent Ion Channels in Cell Membrane: Phylogenetic and Developmental Approaches*. New York: Raven Press.
- Hahn, Matthew W. 2007. "Bias in Phylogenetic Tree Reconciliation Methods: Implications for Vertebrate Genome Evolution." *Genome Biology* 8 (7): R141. doi:10.1186/gb-2007-8-7-r141.
- Hall, Brian K. 1994. *Homology: The Hierarchical Basis of Comparative Biology*. Academic Press.
- Hallen, Heather E, and Frances Trail. 2008. "The L-Type Calcium Ion Channel Cch1 Affects Ascospore Discharge and Mycelial Growth in the Filamentous Fungus *Gibberella Zeae* (Anamorph *Fusarium Graminearum*)." *Eukaryotic Cell* 7 (2): 415–24. doi:10.1128/EC.00248-07.
- Hanson-Smith, Victor, Bryan Kolaczkowski, and Joseph W. Thornton. 2010. "Robustness of Ancestral Sequence Reconstruction to Phylogenetic Uncertainty." *Molecular Biology and Evolution* 27 (9): 1988–99. doi:10.1093/molbev/msq081.
- Hedtke, Shannon M., Ted M. Townsend, and David M. Hillis. 2006. "Resolution of Phylogenetic Conflict in Large Data Sets by Increased Taxon Sampling." *Systematic Biology* 55 (3): 522–29. doi:10.1080/10635150600697358.
- Heinemann, Stefan H., Heinrich Terlau, Walter Stuhmer, Keiji Imoto, and Shosaku Numa. 1992. "Calcium Channel Characteristics Conferred on the Sodium Channel by Single Mutations." *Nature* 356 (6368): 441–43. doi:10.1038/356441a0.
- Hejnol, Andreas, Matthias Obst, Alexandros Stamatakis, Michael Ott, Greg W. Rouse, Gregory D. Edgecombe, Pedro Martinez, et al. 2009. "Assessing the Root of Bilaterian Animals with Scalable Phylogenomic Methods." *Proceedings of the Royal Society B: Biological Sciences* 276 (1677): 4261–70. doi:10.1098/rspb.2009.0896.
- Hess, Peter, and Richard W. Tsien. 1984. "Mechanism of Ion Permeation through Calcium Channels." *Nature* 309 (5967): 453–56. doi:10.1038/309453a0.
- Hill, Alexis S, Atsuo Nishino, Koichi Nakajo, Giuxin Zhang, Jaime R Fineman, Michael E Selzer, Yasushi Okamura, and Edward C Cooper. 2008. "Ion Channel Clustering at the Axon Initial Segment and Node of Ranvier Evolved Sequentially in Early Chordates." *PLoS Genetics* 4 (12): e1000317. doi:10.1371/journal.pgen.1000317.

- Hille, B. 1975. "Ionic Selectivity, Saturation, and Block in Sodium Channels. A Four-Barrier Model." *The Journal of General Physiology* 66 (5): 535–60. doi:10.1085/jgp.66.5.535.
- Hille, Bertil. 1989. "Ionic Channels: Evolutionary Origins and Modern Roles." *Experimental Physiology* 74 (6): 785–804.
- . 2001. *Ion Channels of Excitable Membranes*. 3rd Edition. Sinauer Associates.
- Hodgkin, A. L. 1937a. "Evidence for Electrical Transmission in Nerve. Part 1." *The Journal of Physiology* 90 (2): 183–210.
- . 1937b. "Evidence for Electrical Transmission in Nerve. Part 2." *The Journal of Physiology* 90 (2): 211–32.
- Hodgkin, Alan Lloyd. 1964. "The Ionic Basis of Nervous Conduction." *Science* 145 (3637): 1148–54.
- Hodgkin, A. L., and A. F. Huxley. 1952. "A Quantitative Description of Membrane Current and Its Application to Conduction and Excitation in Nerve." *The Journal of Physiology* 117 (4): 500–544.
- Hodgkin, A. L., and B. Katz. 1949. "The Effect of Sodium Ions on the Electrical Activity of the Giant Axon of the Squid." *The Journal of Physiology* 108 (1): 37–77.
- Hofmann, Hans A. 2010. "The Neuroendocrine Action Potential: Winner of the 2008 Frank Beach Award in Behavioral Neuroendocrinology." *Hormones and Behavior* 58 (4): 555–62. doi:10.1016/j.yhbeh.2010.06.012.
- Holland, Linda Z., João E. Carvalho, Hector Escriva, Vincent Laudet, Michael Schubert, Sebastian M. Shimeld, and Jr-Kai Yu. 2013. "Evolution of Bilaterian Central Nervous Systems: A Single Origin?" *EvoDevo* 4 (1): 27. doi:10.1186/2041-9139-4-27.
- Hong, Min-Pyo, Kiem Vu, Jennifer Bautos, and Angie Gelli. 2010. "Cch1 Restores Intracellular Ca²⁺ in Fungal Cells During Endoplasmic Reticulum Stress." *Journal of Biological Chemistry* 285 (14): 10951–58. doi:10.1074/jbc.M109.056218.
- Huelsenbeck, J P, and F Ronquist. 2001. "MRBAYES: Bayesian Inference of Phylogenetic Trees." *Bioinformatics (Oxford, England)* 17 (8): 754–55.
- Hughes, Austin L. 1994. "The Evolution of Functionally Novel Proteins after Gene Duplication." *Proceedings of the Royal Society of London. Series B: Biological Sciences* 256 (1346): 119–24. doi:10.1098/rspb.1994.0058.
- Ito, Masahiro, Haoxing Xu, Arthur A. Guffanti, Yi Wei, Lior Zvi, David E. Clapham, and Terry A. Krulwich. 2004. "The Voltage-Gated Na⁺ Channel NaVBP Has a Role in Motility, Chemotaxis, and pH Homeostasis of an Alkaliphilic Bacillus." *Proceedings of the National Academy of Sciences of the United States of America* 101 (29): 10566–71. doi:10.1073/pnas.0402692101.
- Jegla, Timothy, Heather Q. Marlow, Bihan Chen, David K. Simmons, Sarah M. Jacobo, and Mark Q. Martindale. 2012. "Expanded Functional Diversity of Shaker K⁺ Channels in Cnidarians Is Driven by Gene Expansion." *PLoS ONE* 7 (12): e51366. doi:10.1371/journal.pone.0051366.

- Jekely, Gaspar. 2011. "Origin and Early Evolution of Neural Circuits for the Control of Ciliary Locomotion." *Proceedings of the Royal Society B: Biological Sciences* 278 (1707): 914–22. doi:10.1098/rspb.2010.2027.
- Jekely, Gaspar, Julien Colombelli, Harald Hausen, Keren Guy, Ernst Stelzer, Francois Nedelec, and Detlev Arendt. 2008. "Mechanism of Phototaxis in Marine Zooplankton." *Nature* 456 (7220): 395–99. doi:10.1038/nature07590.
- Kamada, Takeo. 1934. "Some Observations on Potential Differences Across the Ectoplasm Membrane of Paramecium." *Journal of Experimental Biology* 11 (1): 94–102.
- Katoh, Kazutaka, Kei-ichi Kuma, Hiroyuki Toh, and Takashi Miyata. 2005. "MAFFT Version 5: Improvement in Accuracy of Multiple Sequence Alignment." *Nucleic Acids Research* 33 (2): 511–18. doi:10.1093/nar/gki198.
- Kellenberger, Stephan, and Laurent Schild. 2002. "Epithelial Sodium Channel/Degenerin Family of Ion Channels: A Variety of Functions for a Shared Structure." *Physiological Reviews* 82 (3): 735–67. doi:10.1152/physrev.00007.2002.
- King, Nicole, M. Jody Westbrook, Susan L. Young, Alan Kuo, Monika Abedin, Jarrod Chapman, Stephen Fairclough, et al. 2008. "The Genome of the Choanoflagellate *Monosiga Brevicollis* and the Origin of Metazoans." *Nature* 451 (7180): 783–88. doi:10.1038/nature06617.
- Kirichok, Yuriy, Betsy Navarro, and David E Clapham. 2006. "Whole-Cell Patch-Clamp Measurements of Spermatozoa Reveal an Alkaline-Activated Ca²⁺ Channel." *Nature* 439 (7077): 737–40. doi:10.1038/nature04417.
- Kleinenberg, Nicolaus. 1872. *Hydra: Eine Anatomisch-Entwicklungsgeschichtliche Untersuchung*. W. Engelmann.
- Koishi, Ryuta, Haoxing Xu, Dejian Ren, Betsy Navarro, Benjamin W. Spiller, Qing Shi, and David E. Clapham. 2004. "A Superfamily of Voltage-Gated Sodium Channels in Bacteria." *Journal of Biological Chemistry* 279 (10): 9532–38. doi:10.1074/jbc.M313100200.
- Kulkarni, Nalini H., Akihiko H. Yamamoto, Kellie O. Robinson, Trudy F. C. Mackay, and Robert R. H. Anholt. 2002. "The DSC1 Channel, Encoded by the smi60E Locus, Contributes to Odor-Guided Behavior in *Drosophila Melanogaster*." *Genetics* 161 (4): 1507–16.
- Lartillot, Nicolas, and Hervé Philippe. 2004. "A Bayesian Mixture Model for Across-Site Heterogeneities in the Amino-Acid Replacement Process." *Molecular Biology and Evolution* 21 (6): 1095–1109. doi:10.1093/molbev/msh112.
- Lee, Jung-Ha, Leanne L. Cribbs, and Edward Perez-Reyes. 1999. "Cloning of a Novel Four Repeat Protein Related to Voltage-Gated Sodium and Calcium Channels." *FEBS Letters* 445 (2–3): 231–36. doi:10.1016/S0014-5793(99)00082-4.
- Le, Si Quang, and Olivier Gascuel. 2008. "An Improved General Amino Acid Replacement Matrix." *Molecular Biology and Evolution* 25 (7): 1307–20. doi:10.1093/molbev/msn067.

- Leys, Sally P., and Bernard M. Degnan. 2001. "Cytological Basis of Photoresponsive Behavior in a Sponge Larva." *Biological Bulletin* 201 (3): 323–38. doi:10.2307/1543611.
- Leys, SP, GO Mackie, and RW Meech. 1999. "Impulse Conduction in a Sponge." *J Exp Biol* 202 (9): 1139–50.
- Liao, Ben-Yang, Meng-Pin Weng, and Jianzhi Zhang. 2010. "Contrasting Genetic Paths to Morphological and Physiological Evolution." *Proceedings of the National Academy of Sciences* 107 (16): 7353–58. doi:10.1073/pnas.0910339107.
- Liebeskind, Benjamin J. 2011. "Evolution of Sodium Channels and the New View of Early Nervous System Evolution." *Communicative & Integrative Biology* 4 (6): 679–83. Accessed November 20.
- Liebeskind, Benjamin J., David M. Hillis, and Harold H. Zakon. 2011. "Evolution of Sodium Channels Predates the Origin of Nervous Systems in Animals." *Proceedings of the National Academy of Sciences* 108 (22): 9154–59. doi:10.1073/pnas.1106363108.
- . 2012. "Phylogeny Unites Animal Sodium Leak Channels with Fungal Calcium Channels in an Ancient, Voltage-Insensitive Clade." *Molecular Biology and Evolution* 29 (12): 3613–16. doi:10.1093/molbev/mss182.
- . 2013. "Independent Acquisition of Sodium Selectivity in Bacterial and Animal Sodium Channels." *Current Biology* 23 (21): R948–49. doi:10.1016/j.cub.2013.09.025.
- Liggenstoffer, Audra S, Noha H Youssef, M B Couger, and Mostafa S Elshahed. 2010. "Phylogenetic Diversity and Community Structure of Anaerobic Gut Fungi (phylum Neocallimastigomycota) in Ruminant and Non-Ruminant Herbivores." *The ISME Journal* 4 (10): 1225–35. doi:10.1038/ismej.2010.49.
- Lipkind, Gregory M., and Harry A. Fozzard. 2001. "Modeling of the Outer Vestibule and Selectivity Filter of the L-Type Ca²⁺ Channel†." *Biochemistry* 40 (23): 6786–94. doi:10.1021/bi010269a.
- . 2008. "Voltage-Gated Na Channel Selectivity: The Role of the Conserved Domain III Lysine Residue." *The Journal of General Physiology* 131 (6): 523–29. doi:10.1085/jgp.200809991.
- Liu, Min, Ping Du, Garrett Heinrich, Gary M Cox, and Angie Gelli. 2006. "Cch1 Mediates Calcium Entry in *Cryptococcus Neoformans* and Is Essential in Low-Calcium Environments." *Eukaryotic Cell* 5 (10): 1788–96. doi:10.1128/EC.00158-06.
- Lockery, Shawn R., and Miriam B. Goodman. 2009. "The Quest for Action Potentials in *C. Elegans* Neurons Hits a Plateau." *Nature Neuroscience* 12 (4): 377–78. doi:10.1038/nn0409-377.
- Lu, Boxun, Yanhua Su, Sudipto Das, Jin Liu, Jingsheng Xia, and Dejian Ren. 2007. "The Neuronal Channel NALCN Contributes Resting Sodium Permeability and Is Required for Normal Respiratory Rhythm." *Cell* 129 (2): 371–83. doi:10.1016/j.cell.2007.02.041.

- Lu, Boxun, Yanhua Su, Sudipto Das, Haikun Wang, Yan Wang, Jin Liu, and Dejian Ren. 2009. "Peptide Neurotransmitters Activate a Cation Channel Complex of NALCN and UNC-80." *Nature* 457 (7230): 741–44. doi:10.1038/nature07579.
- Lu, Boxun, Qi Zhang, Haikun Wang, Yan Wang, Manabu Nakayama, and Dejian Ren. 2010. "Extracellular Calcium Controls Background Current and Neuronal Excitability via an UNC79-UNC80-NALCN Cation Channel Complex." *Neuron* 68 (3): 488–99. doi:10.1016/j.neuron.2010.09.014.
- Lucas, Keith. 1909. "The 'all or None' Contraction of the Amphibian Skeletal Muscle Fibre." *The Journal of Physiology* 38 (2-3): 113–33.
- Mackie, George O. 2004. "Central Neural Circuitry in the Jellyfish *Aglantha*." *Neurosignals* 13 (1-2): 5–19.
- Mackie, G. O. 1986. "From Aggregates to Integrates: Physiological Aspects of Modularity in Colonial Animals." *Philosophical Transactions of the Royal Society B: Biological Sciences* 313 (1159): 175–96. doi:10.1098/rstb.1986.0032.
- . 1990. "The Elementary Nervous System Revisited." *American Zoologist* 30 (4): 907–20.
- . 2004. "Epithelial Conduction: Recent Findings, Old Questions, and Where Do We Go from Here?" *Hydrobiologia* 530-531 (1-3): 73–80. doi:10.1007/s10750-004-2644-x.
- Mackie, G. O., C. E. Mills, and C. L. Singla. 1992. "Giant Axons and Escape Swimming in *Euplokamis Dunlapae* (Ctenophora: Cydippida)." *Biol Bull* 182 (2): 248–56.
- Maldonado, Manuel, and Ana Riesgo. 2008. "Reproductive Output in a Mediterranean Population of the Homosclerophorid *Corticium Candelabrum* (Porifera, Demospongiae), with Notes on the Ultrastructure and Behavior of the Larva." *Marine Ecology* 29 (2): 298–316. doi:10.1111/j.1439-0485.2008.00244.x.
- Marlow, Heather Q., Mansi Srivastava, David Q. Matus, Daniel Rokhsar, and Mark Q. Martindale. 2009. "Anatomy and Development of the Nervous System of *Nematostella Vectensis*, an Anthozoan Cnidarian." *Developmental Neurobiology* 69 (4): 235–54. doi:10.1002/dneu.20698.
- Martinac, Boris, Yoshiro Saimi, and Ching Kung. 2008. "Ion Channels in Microbes." *Physiological Reviews* 88 (4): 1449–90. doi:10.1152/physrev.00005.2008.
- Martinson, Alexandra S., Damian B. van Rossum, Fortunay H. Diatta, Michael J. Layden, Sarah A. Rhodes, Mark Q. Martindale, and Timothy Jegla. 2014. "Functional Evolution of Erg Potassium Channel Gating Reveals an Ancient Origin for IKr." *Proceedings of the National Academy of Sciences*, March, 201321716. doi:10.1073/pnas.1321716111.
- Mayr, Ernst. 1988. *Toward a New Philosophy of Biology: Observations of an Evolutionist*. Cambridge, Mass.: Belknap Press of Harvard University Press.
- McGary, Kriston L., Tae Joo Park, John O. Woods, Hye Ji Cha, John B. Wallingford, and Edward M. Marcotte. 2010. "Systematic Discovery of Nonobvious Human Disease Models through Orthologous Phenotypes." *Proceedings of the National Academy of Sciences*, March, 200910200. doi:10.1073/pnas.0910200107.

- McKinney, Wes. 2013. *Python for Data Analysis*. Beijing: O'Reilly.
- Moroz, Leonid L. 2009. "On the Independent Origins of Complex Brains and Neurons." *Brain, Behavior & Evolution* 74 (3): 177–90. doi:10.1159/000258665.
- Moroz, Leonid L., Kevin M. Kocot, Mathew R. Citarella, Sohn Dosung, Tigran P. Norekian, Inna S. Povolotskaya, Anastasia P. Grigorenko, et al. 2014. "The Ctenophore Genome and the Evolutionary Origins of Neural Systems." *Nature* 510 (7503): 109–14. doi:10.1038/nature13400.
- Murata, Yoshimichi, Hirohide Iwasaki, Mari Sasaki, Kazuo Inaba, and Yasushi Okamura. 2005. "Phosphoinositide Phosphatase Activity Coupled to an Intrinsic Voltage Sensor." *Nature* 435 (7046): 1239–43. doi:10.1038/nature03650.
- Nagahora, Hitoshi, Toshiaki Okada, Naoya Yahagi, Jayhong Andrew Chong, Gail Mandel, and Yasushi Okamura. 2000. "Diversity of Voltage-Gated Sodium Channels in the Ascidian Larval Nervous System." *Biochemical and Biophysical Research Communications* 275 (2): 558–64. doi:10.1006/bbrc.2000.3290.
- Nash, Howard A., Robert L. Scott, Bridget C. Lear, and Ravi Allada. 2002. "An Unusual Cation Channel Mediates Photic Control of Locomotion in *Drosophila*." *Current Biology* 12 (24): 2152–58. doi:10.1016/S0960-9822(02)01358-1.
- Nielsen, Claus. 2008. "Six Major Steps in Animal Evolution: Are We Derived Sponge Larvae?" *Evolution & Development* 10 (2): 241–57. doi:10.1111/j.1525-142X.2008.00231.x.
- Nylander, Johan A A, James C Wilgenbusch, Dan L Warren, and David L Swofford. 2008. "AWTY (are We There Yet?): A System for Graphical Exploration of MCMC Convergence in Bayesian Phylogenetics." *Bioinformatics (Oxford, England)* 24 (4): 581–83. doi:10.1093/bioinformatics/btm388.
- Ohno, Susumu. 1970. *Evolution by Gene Duplication*. London, New York: Allen & Unwin; Springer-Verlag.
- Paidhungat, M, and S Garrett. 1997. "A Homolog of Mammalian, Voltage-Gated Calcium Channels Mediates Yeast Pheromone-Stimulated Ca²⁺ Uptake and Exacerbates the *cdc1(Ts)* Growth Defect." *Molecular and Cellular Biology* 17 (11): 6339–47.
- Pang, Kevin, and Mark Q Martindale. 2008. "Developmental Expression of Homeobox Genes in the Ctenophore *Mnemiopsis leidyi*." *Development Genes and Evolution* 218 (6): 307–19. doi:10.1007/s00427-008-0222-3.
- Pantin, C. F. A. 1952. "Croonian Lecture: The Elementary Nervous System." *Proceedings of the Royal Society of London. Series B - Biological Sciences* 140 (899): 147–68. doi:10.1098/rspb.1952.0052.
- Parfrey, Laura Wegener, Daniel J. G. Lahr, Andrew H. Knoll, and Laura A. Katz. 2011. "Estimating the Timing of Early Eukaryotic Diversification with Multigene Molecular Clocks." *Proceedings of the National Academy of Sciences* 108 (33): 13624–29. doi:10.1073/pnas.1110633108.
- Parker, George Howard. 1919. *The Elementary Nervous System*. JB Lippincott Company.

- Passano, L. M. 1963. "Primitive Nervous Systems" *Proceedings of the National Academy of Sciences of the United States of America* 50 (2): 306–13.
- Payandeh, Jian, and Daniel L. Minor Jr. 2014. "Bacterial Voltage-Gated Sodium Channels (BacNaVs) from the Soil, Sea, and Salt Lakes Enlighten Molecular Mechanisms of Electrical Signaling and Pharmacology in the Brain and Heart." *Journal of Molecular Biology*. Accessed August 28. doi:10.1016/j.jmb.2014.08.010.
- Payandeh, Jian, Todd Scheuer, Ning Zheng, and William A. Catterall. 2011. "The Crystal Structure of a Voltage-Gated Sodium Channel." *Nature* 475 (7356): 353–58. doi:10.1038/nature10238.
- Pearse, Vicki Buchsbaum, and Oliver Voigt. 2007. "Field Biology of Placozoans (Trichoplax): Distribution, Diversity, Biotic Interactions." *Integrative and Comparative Biology* 47 (5): 677–92. doi:10.1093/icb/icm015.
- Penn, O., E. Privman, G. Landan, D. Graur, and T. Pupko. 2010. "An Alignment Confidence Score Capturing Robustness to Guide Tree Uncertainty." *Molecular Biology and Evolution* 27 (8): 1759–67. doi:10.1093/molbev/msq066.
- Philippe, Hervé, Henner Brinkmann, Dennis V. Lavrov, D. Timothy J. Littlewood, Michael Manuel, Gert Wörheide, and Denis Baurain. 2011. "Resolving Difficult Phylogenetic Questions: Why More Sequences Are Not Enough." *PLoS Biol* 9 (3): e1000602. doi:10.1371/journal.pbio.1000602.
- Philippe, Hervé, Romain Derelle, Philippe Lopez, Kerstin Pick, Carole Borchellini, Nicole Boury-Esnault, Jean Vacelet, et al. 2009. "Phylogenomics Revives Traditional Views on Deep Animal Relationships." *Current Biology* 19 (8): 706–12. doi:10.1016/j.cub.2009.02.052.
- Piccolino, Marco, and Marco Bresadola. 2002. "Drawing a Spark from Darkness: John Walsh and Electric Fish." *Trends in Neurosciences* 25 (1): 51–57. doi:10.1016/S0166-2236(00)02003-8.
- Pick, K.S., H. Philippe, F. Schreiber, D. Erpenbeck, D.J. Jackson, P. Wrede, M. Wiens, et al. 2010. "Improved Phylogenomic Taxon Sampling Noticeably Affects Nonbilaterian Relationships." *Molecular Biology and Evolution* 27 (9): 1983–87. doi:10.1093/molbev/msq089.
- Pierce-Shimomura, Jonathan T, Beth L Chen, James J Mun, Raymond Ho, Raman Sarkis, and Steven L McIntire. 2008. "Genetic Analysis of Crawling and Swimming Locomotory Patterns in *C. Elegans*." *Proceedings of the National Academy of Sciences* 105 (52): 20982–87. doi:10.1073/pnas.0810359105.
- Prole, David L., and Colin W. Taylor. 2011. "Identification of Intracellular and Plasma Membrane Calcium Channel Homologues in Pathogenic Parasites." *PLoS ONE* 6 (10): e26218. doi:10.1371/journal.pone.0026218.
- Punta, M., P. C. Coghill, R. Y. Eberhardt, J. Mistry, J. Tate, C. Boursnell, N. Pang, et al. 2011. "The Pfam Protein Families Database." *Nucleic Acids Research* 40 (D1): D290–301. doi:10.1093/nar/gkr1065.

- Rambaut, A, and AJ Drummond. “Tracer v1.4, Available from <http://beast.bio.ed.ac.uk/Tracer>.”
- Rassat, Jürgen, and August Ruthmann. 1979. “Trichoplax Adhaerens FE Schulze (Placozoa) in the Scanning Electron Microscope.” *Zoomorphologie* 93 (1): 59–72.
- R Development Core Team. 2008. *R: A Language and Environment for Statistical Computing*. Vienna, Austria: R Foundation for Statistical Computing. <http://www.R-project.org>.
- Reid, John D., Wilma Lukas, Reza Shafaatian, Adam Bertl, Carsten Scheurmann-Kettner, H. Robert Guy, and R. Alan North. 1995. “The S. Cerevisiae Outwardly-Rectifying Potassium Channel (DUK1) Identifies a New Family of Channels with Duplicated Pore Domains.” *Receptors & Channels* 4 (1): 51–62.
- Ren, Dejian. 2011. “Sodium Leak Channels in Neuronal Excitability and Rhythmic Behaviors.” *Neuron* 72 (6): 899–911. doi:10.1016/j.neuron.2011.12.007.
- Ren, Dejian, Betsy Navarro, Haoxing Xu, Lixia Yue, Qing Shi, and David E. Clapham. 2001. “A Prokaryotic Voltage-Gated Sodium Channel.” *Science* 294 (5550): 2372–75. doi:10.1126/science.1065635.
- Reynolds, Edward H. 2004. “Todd, Faraday, and the Electrical Basis of Brain Activity.” *The Lancet Neurology* 3 (9): 557–63. doi:10.1016/S1474-4422(04)00842-7.
- Richter, Daniel J., and Nicole King. 2013. “The Genomic and Cellular Foundations of Animal Origins.” *Annual Review of Genetics* 47 (1): 509–37. doi:10.1146/annurev-genet-111212-133456.
- Rokas, Antonis, Dirk Krüger, and Sean B. Carroll. 2005. “Animal Evolution and the Molecular Signature of Radiations Compressed in Time.” *Science* 310 (5756): 1933–38. doi:10.1126/science.1116759.
- Roth, V. Louise. 1991. “Homology and Hierarchies: Problems Solved and Unresolved.” *Journal of Evolutionary Biology* 4 (2): 167–94.
- Ryan, Joseph F. 2014. “Did the Ctenophore Nervous System Evolve Independently?” *Zoology* 117 (4): 225–26. doi:10.1016/j.zool.2014.06.001.
- Ryan, Joseph F., Kevin Pang, Christine E. Schnitzler, Anh-Dao Nguyen, R. Travis Moreland, David K. Simmons, Bernard J. Koch, et al. 2013. “The Genome of the Ctenophore Mnemiopsis leidyi and Its Implications for Cell Type Evolution.” *Science* 342 (6164): 1242592. doi:10.1126/science.1242592.
- Sachs, Joe. 1995. *Aristotle’s Physics: A Guided Study*. Masterworks of Discovery. New Brunswick, N.J: Rutgers University Press.
- Saier, Milton H., Can V. Tran, and Ravi D. Barabote. 2006. “TCDB: The Transporter Classification Database for Membrane Transport Protein Analyses and Information.” *Nucleic Acids Research* 34 (suppl 1): D181–86. doi:10.1093/nar/gkj001.
- Sakarya, Onur, Kathryn A. Armstrong, Maja Adamska, Marcin Adamski, I-Fan Wang, Bruce Tidor, Bernard M. Degnan, Todd H. Oakley, and Kenneth S. Kosik. 2007. “A Post-Synaptic Scaffold at the Origin of the Animal Kingdom.” *PLoS ONE* 2 (6): e506. doi:10.1371/journal.pone.0000506.

- Sakarya, Onur, Kenneth S. Kosik, and Todd H. Oakley. 2008. "Reconstructing Ancestral Genome Content Based on Symmetrical Best Alignments and Dollo Parsimony." *Bioinformatics* 24 (5): 606–12. doi:10.1093/bioinformatics/btn005.
- Sather, William A., and Edwin W. McCleskey. 2003. "Permeation and Selectivity in Calcium Channels." *Annual Review of Physiology* 65 (1): 133–59. doi:10.1146/annurev.physiol.65.092101.142345.
- Sato, Chikara, Yutaka Ueno, Kiyoshi Asai, Katsutoshi Takahashi, Masahiko Sato, Andreas Engel, and Yoshinori Fujiyoshi. 2001. "The Voltage-Sensitive Sodium Channel Is a Bell-Shaped Molecule with Several Cavities." *Nature* 409 (6823): 1047–51. doi:10.1038/35059098.
- Satterlie, Richard A. 2011. "Do Jellyfish Have Central Nervous Systems?" *J Exp Biol* 214 (8): 1215–23. doi:10.1242/jeb.043687.
- Schlief, Thomas, Roland Schonherr, Keiji Imoto, and S. H. Heinemann. 1996. "Pore Properties of Rat Brain II Sodium Channels Mutated in the Selectivity Filter Domain." *European Biophysics Journal* 25 (December): 75–91. doi:10.1007/s002490050020.
- Schnell, Jason R., and James J. Chou. 2008. "Structure and Mechanism of the M2 Proton Channel of Influenza A Virus." *Nature* 451 (7178): 591–95. doi:10.1038/nature06531.
- Schubert, Ulrich, Antonio V. Ferrer-Montiel, Myrta Oblatt-Montal, Peter Henklein, Klaus Strebel, and Mauricio Montal. 1996. "Identification of an Ion Channel Activity of the Vpu Transmembrane Domain and Its Involvement in the Regulation of Virus Release from HIV-1-Infected Cells." *FEBS Letters* 398 (1): 12–18. doi:10.1016/S0014-5793(96)01146-5.
- Senatore, Adriano, Wendy Guan, Adrienne N. Boone, and J. David Spafford. 2014. "T-Type Channels Become Highly Permeable to Sodium Ions Using an Alternate Extracellular Turret Region (S5-P) Outside the Selectivity Filter." *Journal of Biological Chemistry*, March, jbc.M114.551473. doi:10.1074/jbc.M114.551473.
- Senatore, Adriano, Arnaud Monteil, Jan van Minnen, August B. Smit, and J. David Spafford. 2013. "NALCN Ion Channels Have Alternative Selectivity Filters Resembling Calcium Channels or Sodium Channels." *PLoS ONE* 8 (1): e55088. doi:10.1371/journal.pone.0055088.
- Shaya, David, Mohamed Kreir, Rebecca A Robbins, Stephanie Wong, Justus Hammon, Andrea Brüggemann, and Daniel L Minor Jr. 2011. "Voltage-Gated Sodium Channel (NaV) Protein Dissection Creates a Set of Functional Pore-Only Proteins." *Proceedings of the National Academy of Sciences of the United States of America* 108 (30): 12313–18. doi:10.1073/pnas.1106811108.
- Shubin, Neil, Cliff Tabin, and Sean Carroll. 2009. "Deep Homology and the Origins of Evolutionary Novelty." *Nature* 457 (7231): 818–23. doi:10.1038/nature07891.
- Signorovitch, Ana Y., Stephen L. Dellaporta, and Leo W. Buss. 2005. "Molecular Signatures for Sex in the Placozoa." *Proceedings of the National Academy of*

- Sciences of the United States of America* 102 (43): 15518–22.
doi:10.1073/pnas.0504031102.
- Simons, P.j. 1981. “The Role of Electricity in Plant Movements.” *New Phytologist* 87 (1): 11–37. doi:10.1111/j.1469-8137.1981.tb01687.x.
- Sirota, Fernanda L., Pedro G. Pascutti, and Celia Anteneodo. 2002. “Molecular Modeling and Dynamics of the Sodium Channel Inactivation Gate.” *Biophysical Journal* 82 (3): 1207–15. doi:10.1016/S0006-3495(02)75477-5.
- Smith, John Maynard. 1970. “Natural Selection and the Concept of a Protein Space.”
- Smith, M.R., and A.L. Goldin. 1997. “Interaction between the Sodium Channel Inactivation Linker and Domain III S4-S5.” *Biophysical Journal* 73 (4): 1885–95. doi:10.1016/S0006-3495(97)78219-5.
- Spafford, J. David, Andrew N. Spencer, and Warren J. Gallin. 1998. “A Putative Voltage-Gated Sodium Channel [alpha] Subunit (PpSCN1) from the Hydrozoan Jellyfish, *Polyorchis penicillatus*: Structural Comparisons and Evolutionary Considerations.” *Biochemical and Biophysical Research Communications* 244 (3): 772–80. doi:10.1006/bbrc.1998.8332.
- Spencer, A. N., and R. A. Satterlie. 1981. “The Action Potential and Contraction in Subumbrellar Swimming Muscle of *Polyorchis penicillatus* (Hydromedusae).” *Journal of Comparative Physiology ? A* 144 (3): 401–7. doi:10.1007/BF00612572.
- Srivastava, Mansi, Emina Begovic, Jarrod Chapman, Nicholas H. Putnam, Uffe Hellsten, Takeshi Kawashima, Alan Kuo, et al. 2008. “The Trichoplax Genome and the Nature of Placozoans.” *Nature* 454 (7207): 955–60. doi:10.1038/nature07191.
- Stamatakis, Alexandros. 2006. “RAxML-VI-HPC: Maximum Likelihood-Based Phylogenetic Analyses with Thousands of Taxa and Mixed Models.” *Bioinformatics* 22 (21): 2688–90. doi:10.1093/bioinformatics/btl446.
- Steinmetz, Patrick R.H., Johanna E.M. Kraus, Claire Larroux, Jorg U. Hammel, Annette Amon-Hassenzahl, Evelyn Houlston, Gert Worheide, Michael Nickel, Bernard M. Degnan, and Ulrich Technau. 2012. “Independent Evolution of Striated Muscles in Cnidarians and Bilaterians.” *Nature* 487 (7406): 231–34. doi:10.1038/nature11180.
- Stoltzfus, Arlin. 1999. “On the Possibility of Constructive Neutral Evolution.” *Journal of Molecular Evolution* 49 (2): 169–81. doi:10.1007/PL00006540.
- Strong, M., K. G. Chandy, and G. A. Gutman. 1993. “Molecular Evolution of Voltage-Sensitive Ion Channel Genes: On the Origins of Electrical Excitability.” *Molecular Biology and Evolution* 10 (1): 221–42.
- Sukumaran, Jeet, and Mark T. Holder. 2010. “DendroPy: A Python Library for Phylogenetic Computing.” *Bioinformatics* 26 (12): 1569–71. doi:10.1093/bioinformatics/btq228.
- Swayne, Leigh Anne, Alexandre Mezghrani, Annie Varrault, Jean Chemin, Gyslaine Bertrand, Stephane Dalle, Emmanuel Bourinet, et al. 2009. “The NALCN Ion

- Channel Is Activated by M3 Muscarinic Receptors in a Pancreatic [beta]-Cell Line.” *EMBO Rep* 10 (8): 873–80. doi:10.1038/embor.2009.125.
- Swofford, David L. 2003. *Phylogenetic Analysis Using Parsimony (*and Other Methods)* (version 4.0). Sunderland, MA: Sinauer Associates.
- Tang, Lin, Tamer M. Gamal El-Din, Jian Payandeh, Gilbert Q. Martinez, Teresa M. Heard, Todd Scheuer, Ning Zheng, and William A. Catterall. 2014. “Structural Basis for Ca²⁺ Selectivity of a Voltage-Gated Calcium Channel.” *Nature* 505 (7481): 56–61. doi:10.1038/nature12775.
- Taylor, Alison, and Colin Brownlee. 1993. “Calcium and Potassium Currents in the Fucus Egg.” *Planta* 189 (January). doi:10.1007/BF00201351.
- Teng, Jinfeng, Rika Goto, Kazuko Iida, Itaru Kojima, and Hidetoshi Iida. 2008. “Ion-Channel Blocker Sensitivity of Voltage-Gated Calcium-Channel Homologue Cch1 in *Saccharomyces Cerevisiae*.” *Microbiology* 154 (12): 3775–81. doi:10.1099/mic.0.2008/021089-0.
- Tinbergen, N. 1963. “On Aims and Methods of Ethology.” *Zeitschrift Für Tierpsychologie* 20 (4): 410–33. doi:10.1111/j.1439-0310.1963.tb01161.x.
- Torruella, Guifré, Romain Derelle, Jordi Paps, B. Franz Lang, Andrew J. Roger, Kamran Shalchian-Tabrizi, and Iñaki Ruiz-Trillo. 2011. “Phylogenetic Relationships within the Opisthokonta Based on Phylogenomic Analyses of Conserved Single Copy Protein Domains.” *Molecular Biology and Evolution*, July. doi:10.1093/molbev/msr185.
- True, John R., and Eric S. Haag. 2001. “Developmental System Drift and Flexibility in Evolutionary Trajectories.” *Evolution and Development* 3 (2): 109–19. doi:10.1046/j.1525-142x.2001.003002109.x.
- Verkhatsky, Alexei, O. A. Krishtal, and Ole H. Petersen. 2006. “From Galvani to Patch Clamp: The Development of Electrophysiology.” *Pflügers Archiv* 453 (3): 233–47. doi:10.1007/s00424-006-0169-z.
- Verret, Frédéric, Glen Wheeler, Alison R. Taylor, Garry Farnham, and Colin Brownlee. 2010. “Calcium Channels in Photosynthetic Eukaryotes: Implications for Evolution of Calcium-Based Signalling.” *New Phytologist* 187 (1): 23–43.
- Vu, Vincent Q. 2011. *Ggbiplot: A ggplot2 Based Biplot*. <http://github.com/vqv/ggbiplot>.
- Wallace, Wes. 2003. “The Vibrating Nerve Impulse in Newton, Willis and Gassendi: First Steps in a Mechanical Theory of Communication.” *Brain and Cognition* 51 (1): 66–94. doi:10.1016/S0278-2626(02)00513-4.
- Wang, Xiang, Xiaoli Zhang, Xian-ping Dong, Mohammad Samie, Xinran Li, Xiping Cheng, Andrew Goschka, et al. 2012. “TPC Proteins Are Phosphoinositide-Activated Sodium-Selective Ion Channels in Endosomes and Lysosomes.” *Cell* 151 (2): 372–83. doi:10.1016/j.cell.2012.08.036.
- Watanabe, Hiroshi, Toshitaka Fujisawa, and Thomas W. Holstein. 2009. “Cnidarians and the Evolutionary Origin of the Nervous System.” *Development, Growth & Differentiation* 51 (3): 167–83. doi:10.1111/j.1440-169X.2009.01103.x.

- Wemmie, John A., Jianguo Chen, Candice C. Askwith, Alesia M. Hruska-Hageman, Margaret P. Price, Brian C. Nolan, Patrick G. Yoder, et al. 2002. "The Acid-Activated Ion Channel ASIC Contributes to Synaptic Plasticity, Learning, and Memory." *Neuron* 34 (3): 463–77. doi:10.1016/S0896-6273(02)00661-X.
- Wheeler, Glen L., and Colin Brownlee. 2008. "Ca²⁺ Signalling in Plants and Green Algae - Changing Channels." *Trends in Plant Science* 13 (9): 506–14. doi:10.1016/j.tplants.2008.06.004.
- Whelan, Simon, and Nick Goldman. 2001. "A General Empirical Model of Protein Evolution Derived from Multiple Protein Families Using a Maximum-Likelihood Approach." *Molecular Biology and Evolution* 18 (5): 691–99.
- White, Gena B., Arnold Pfahnl, Steven Haddock, Susanna Lamers, Robert M. Greenberg, and Peter A. V. Anderson. 1998. "Structure of a Putative Sodium Channel from the Sea anemone *Aiptasia Pallida*." *Invertebrate Neuroscience* 3 (4): 317–26. doi:10.1007/BF02577691.
- Yang, Jian, Patrick T. Ellnor, William A. Sather, Ji-Fang Zhang, and Richard W. Tsien. 1993. "Molecular Determinants of Ca²⁺ Selectivity and Ion Permeation in L-Type Ca²⁺ Channels" 366 (6451): 158. doi:10.1038/366158a0.
- Yang, Ziheng. 2007. "PAML 4: Phylogenetic Analysis by Maximum Likelihood." *Molecular Biology and Evolution* 24 (8): 1586–91. doi:10.1093/molbev/msm088.
- Yue, Lixia, Betsy Navarro, Dejian Ren, Arnolt Ramos, and David E. Clapham. 2002. "The Cation Selectivity Filter of the Bacterial Sodium Channel, NaChBac." *The Journal of General Physiology* 120 (6): 845–53. doi:10.1085/jgp.20028699.
- Zakon, Harold H, Manda C Jost, and Ying Lu. 2011a. "Expansion of Voltage-Dependent Na⁺ Channel Gene Family in Early Tetrapods Coincided with the Emergence of Terrestriality and Increased Brain Complexity." *Molecular Biology and Evolution* 28 (4): 1415–24. doi:10.1093/molbev/msq325.
- Zakon, Harold H., Manda C. Jost, and Ying Lu. 2011b. "Expansion of Voltage-Dependent Na⁺ Channel Gene Family in Early Tetrapods Coincided with the Emergence of Terrestriality and Increased Brain Complexity." *Molecular Biology and Evolution* 28 (4): 1415–24. doi:10.1093/molbev/msq325.
- Zelter, Alex, Mojca Bencina, Barry J Bowman, Oded Yarden, and Nick D Read. 2004. "A Comparative Genomic Analysis of the Calcium Signaling Machinery in *Neurospora Crassa*, *Magnaporthe Grisea*, and *Saccharomyces Cerevisiae*." *Fungal Genetics and Biology* 41 (9): 827–41. doi:10.1016/j.fgb.2004.05.001.
- Zhou, Wei, Inbum Chung, Zhiqi Liu, Alan L Goldin, and Ke Dong. 2004. "A Voltage-Gated Calcium-Selective Channel Encoded by a Sodium Channel-like Gene." *Neuron* 42 (1): 101–12. doi:10.1016/S0896-6273(04)00148-5.
- Zhu, Michael X., Jianjie Ma, John Parrington, Peter J. Calcraft, Antony Galione, and A. Mark Evans. 2010. "Calcium Signaling via Two-Pore Channels: Local or Global, That Is the Question." *American Journal of Physiology. Cell Physiology* 298 (3): C430–41. doi:10.1152/ajpcell.00475.2009.

Zwickl, Derrick J. 2006. "Genetic Algorithm Approaches for the Phylogenetic Analysis of Large Biological Sequence Datasets under the Maximum Likelihood Criterion." Ph.D. dissertation, The University of Texas at Austin.